

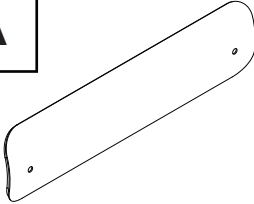

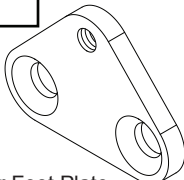

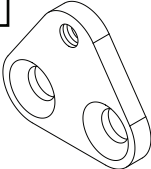



# FORD RANGER OE SPORTBAR TO *SPORTLID V* INSTALLATION

KIT NUMBER  
**10055936**  
STANDARD OE BAR  
Part No# FOAMAB3J2155174BA

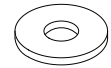
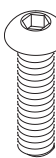
KIT NUMBER  
**10055935**  
OE BAR WITH CARGO LIGHTS  
Part No# FO-VGB3Z 2155106 B

<b>A</b> X1  Brake Light Cover	<b>B</b> X2  Rear Foot Plate	<b>C</b> X2  Front Foot Plate	<b>D</b> X4  M8 Spring Washer	<b>E</b> X1  FORD OE BAR 4 PIN EXTENSION 10055319		
<b>F</b> X4  M8x19mm Washer	<b>G</b> X4  M6x22x3mm EPDM Washer	<b>H</b> X4  M8x30mm Bolt	<b>I</b> X4  22mm Cap	<b>J</b> X8  M8x20mm CS Bolt	<b>K</b> X4  M8x24x2mm Washer	<b>L</b> X1  FORD CHMSL LOOM KIT 10055934
<p>◇ = EXISTING PART ○ = NEW PART</p>	<p><b>Tools required</b> Ø22mm Hole Saw Ø12mm, Ø10mm Drill Bits Non-Acetic Neutral-Cure Silicone</p>		<p>Loctite 243 5mm Hex Key Masking Tape Caulking Gun Utility Knife</p>		<p>Drill</p>	<p>PARTS SUPPLIED SEPERATELY PART D = OE BAR WITH CARGO LIGHTS PART K = STANDARD OE BAR FOLLOW COLOUR CODED STEPS</p>

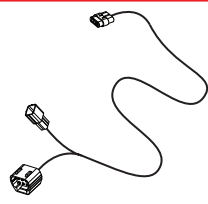
## IMPORTANT! to take care and drill correct holes

See fitting instructions for the SPORTLID V fitment until prompted to see these OE Bar fitting instructions (10055998)

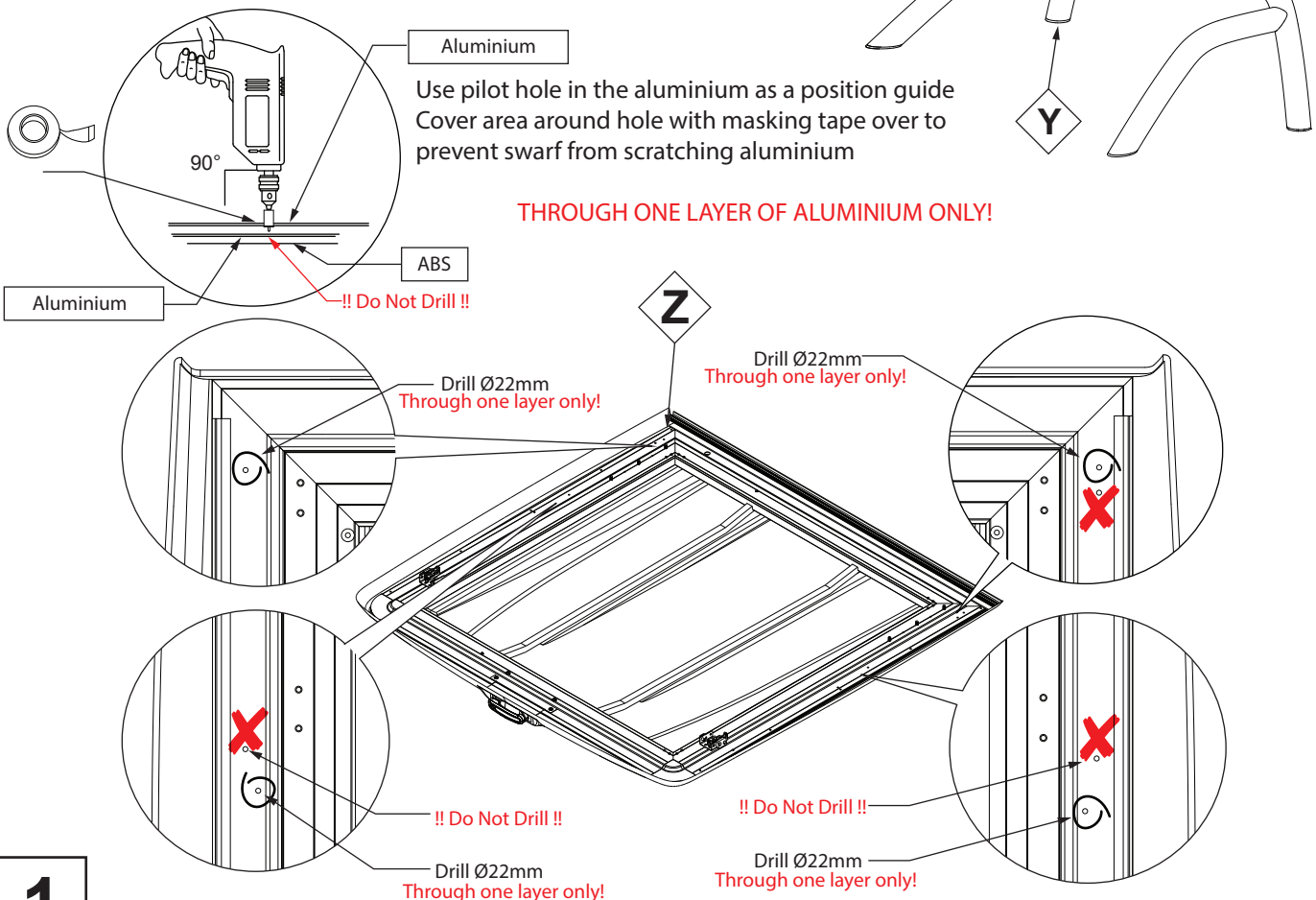

**1**

Instruction Number	Manufacturer	Model Type	Year	Stockist	Cab Size	Product	Revision	Date	Page
10055898	Ford	Ranger	2011	-	DC	Ford OE Bar	2	22-10-19	1 of 8

**IMPORTANT!** to take care and drill correct holes

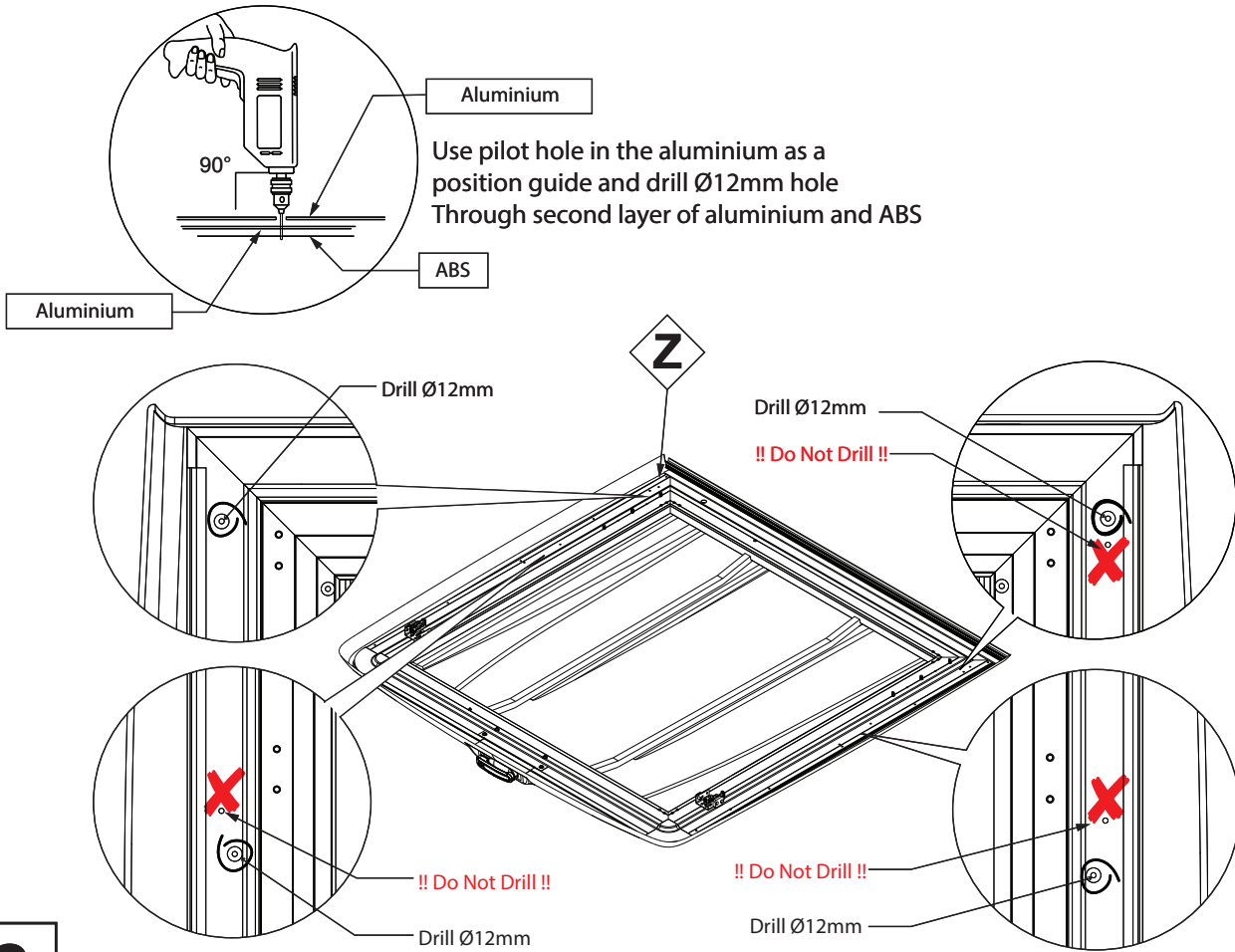

**2**

**IMPORTANT!** to take care and drill correct holes

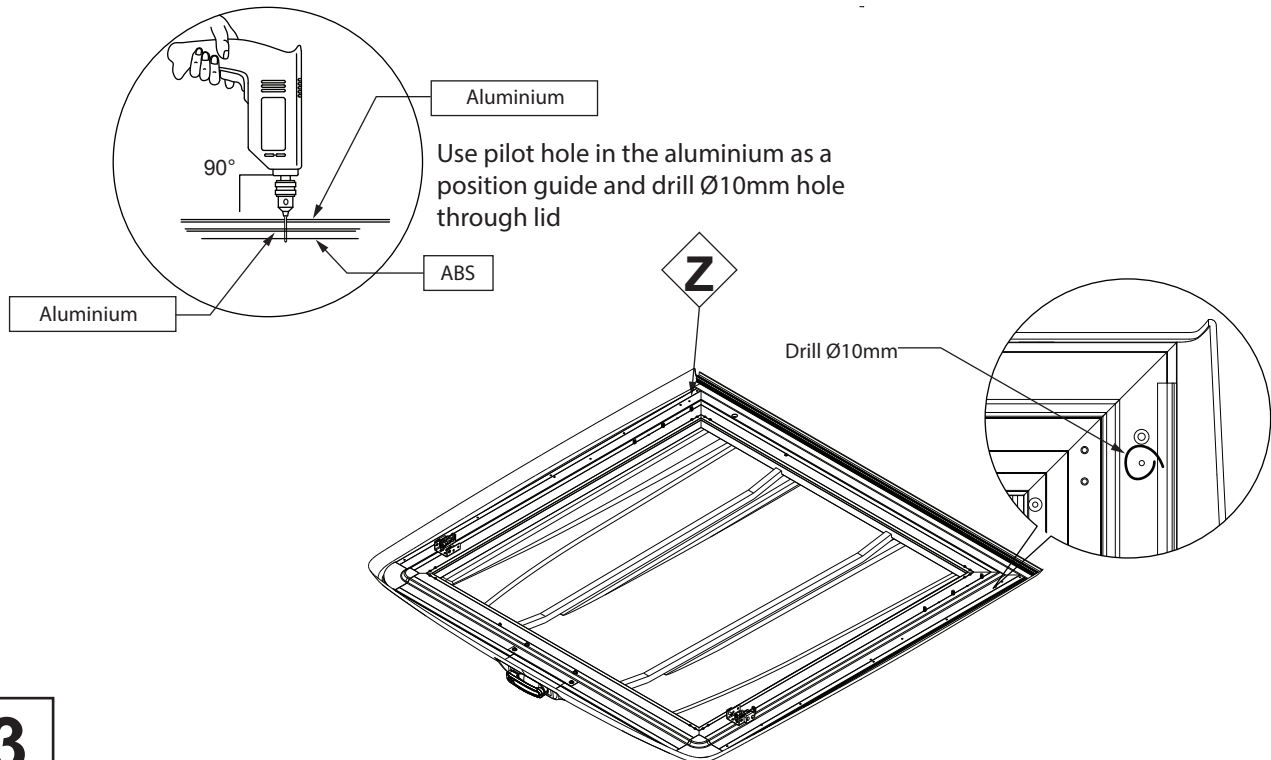

**3**

Instruction Number	Manufacturer	Model Type	Year	Stockist	Cab Size	Product	Revision	Date	Page
10055898	Ford	Ranger	2011	-	DC	Ford OE Bar	2	22-10-19	2 of 8

FOLLOW STEPS 4 - 8 FOR VEHICLES WITH REAR CAB STOP LIGHT

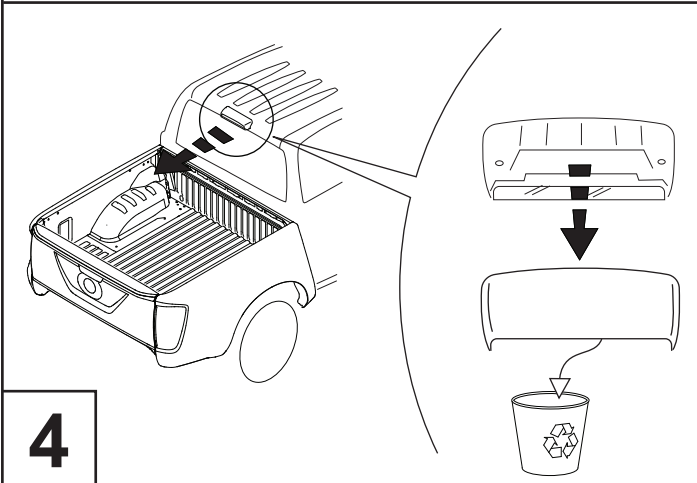

4

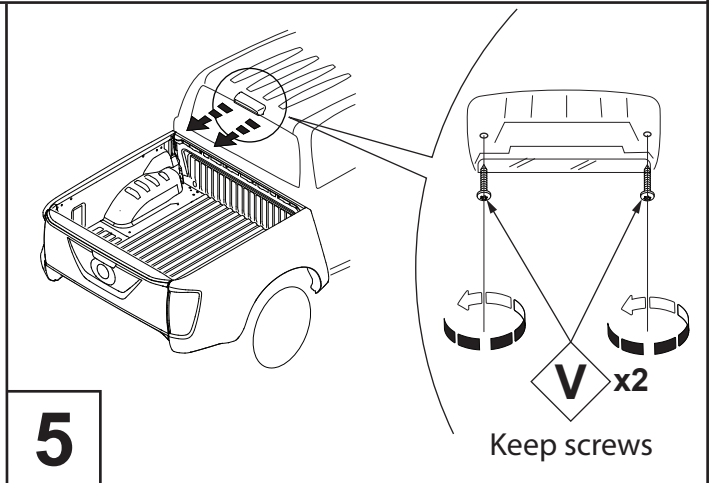

5

Keep screws

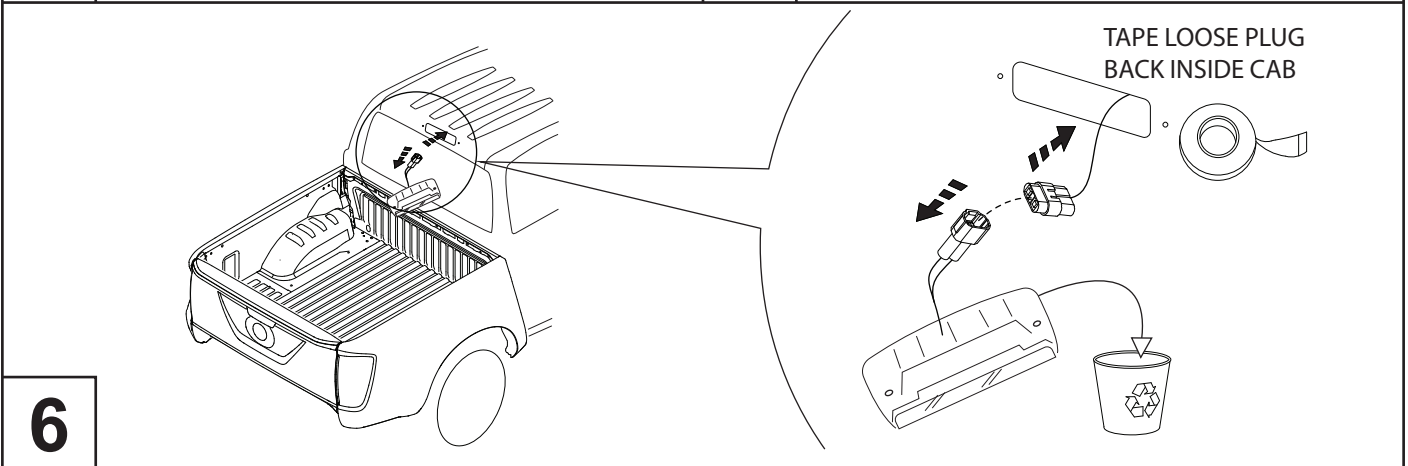

6

TAP LOOSE PLUG  
BACK INSIDE CAB

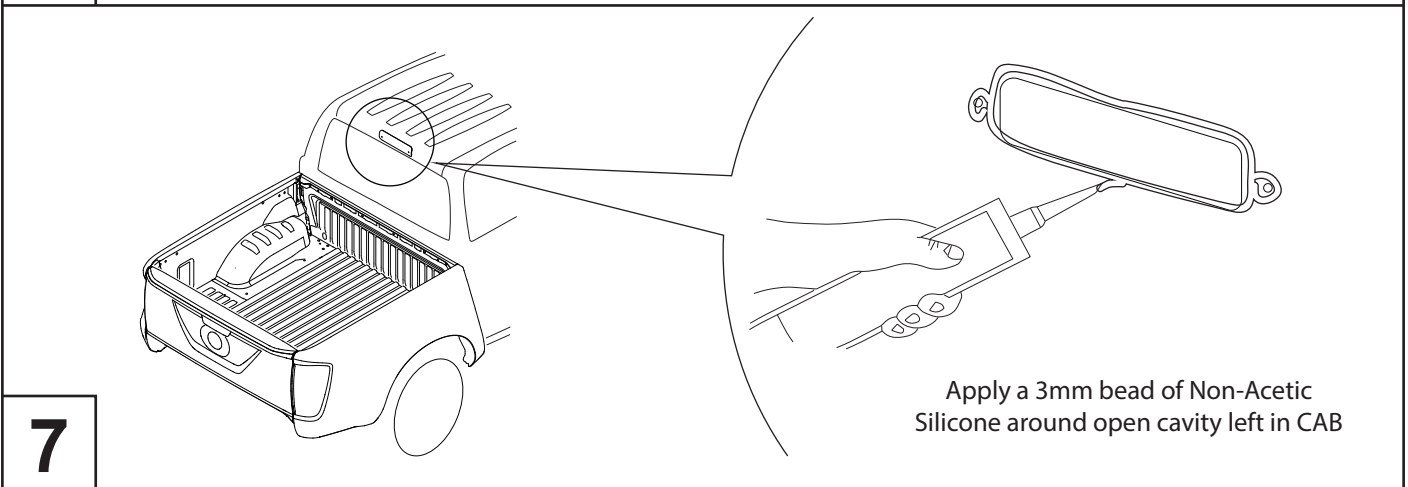

7

Apply a 3mm bead of Non-Acetic  
Silicone around open cavity left in CAB

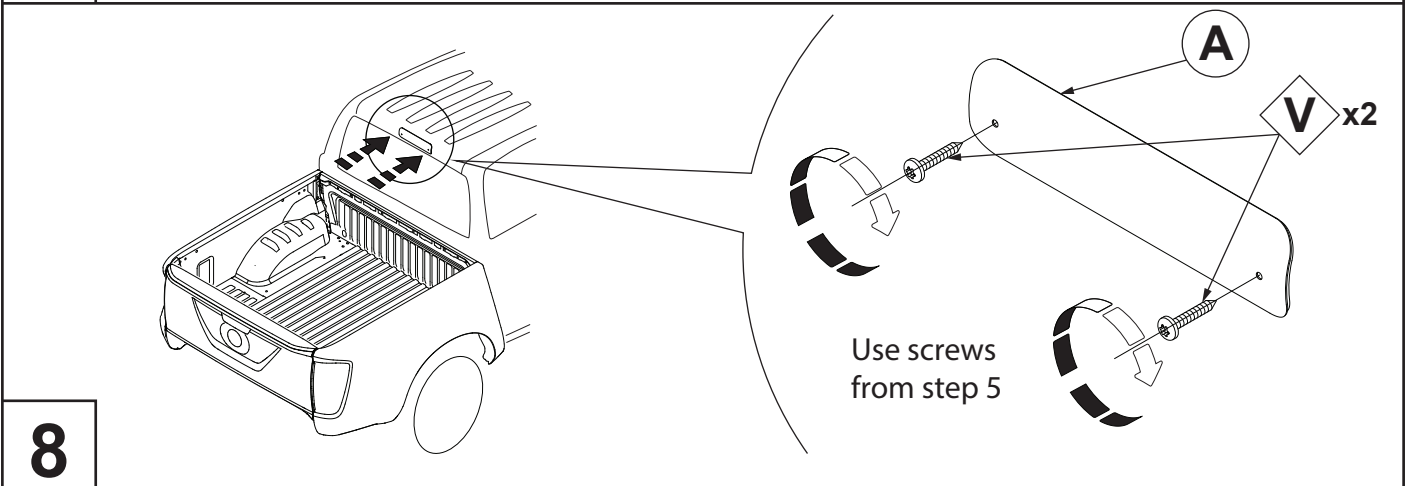

8

Use screws  
from step 5

Instruction Number	Manufacturer	Model Type	Year	Stockist	Cab Size	Product	Revision	Date	Page
10055898	Ford	Ranger	2011	-	DC	Ford OE Bar	2	22-10-19	3 of 8

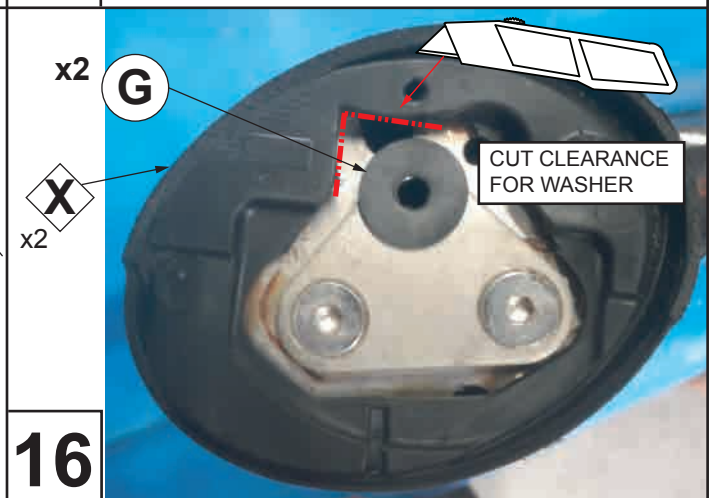
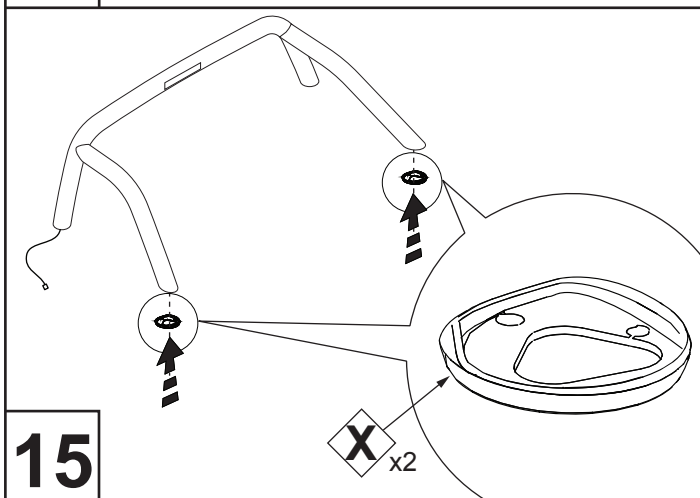
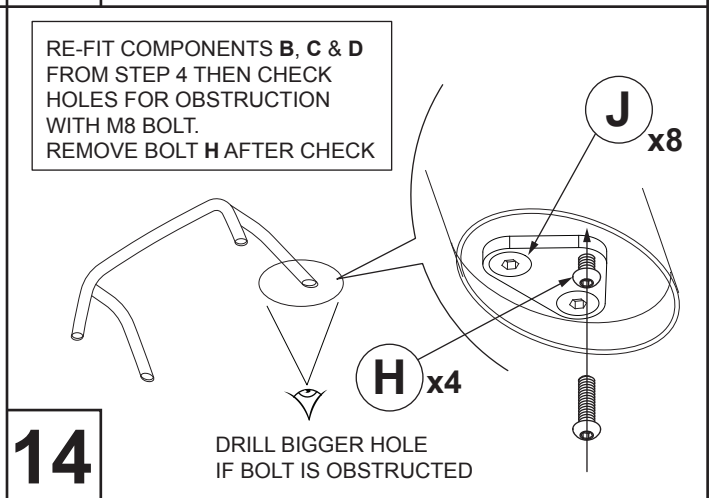
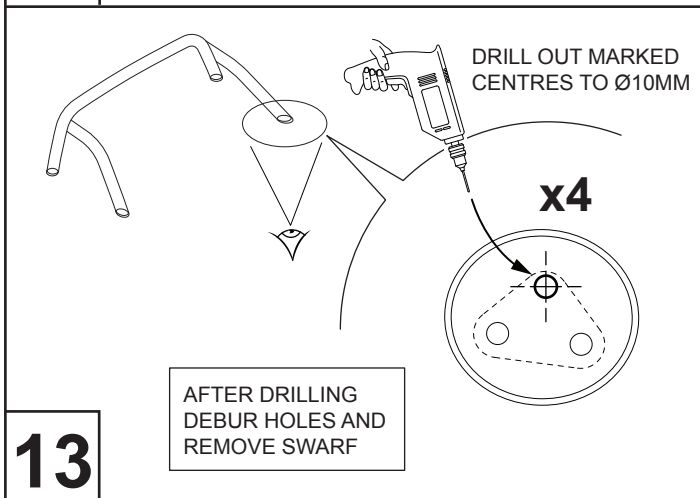
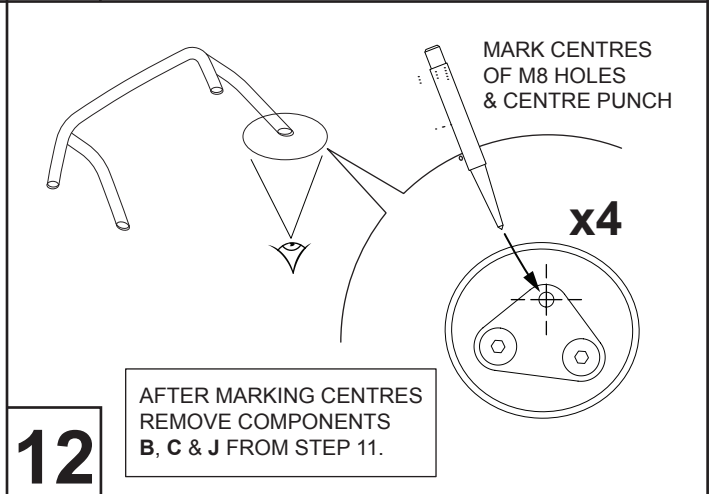
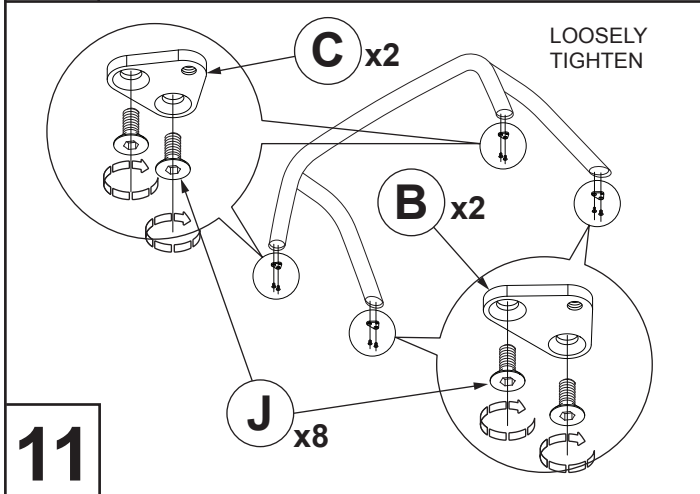
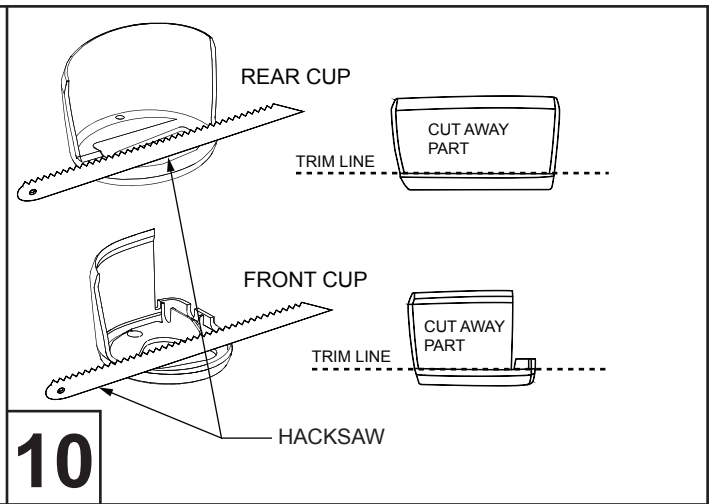
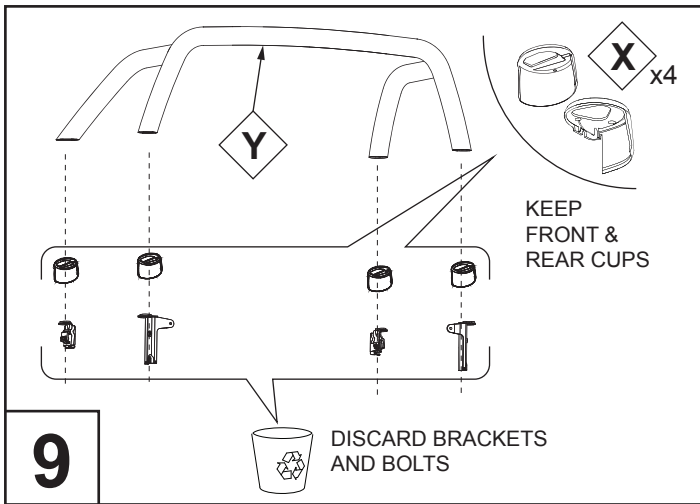

Instruction Number	Manufacturer	Model Type	Year	Stockist	Cab Size	Product	Revision	Date	Page
10055898	Ford	Ranger	2011	-	DC	Ford OE Bar	2	22-10-19	4 of 8

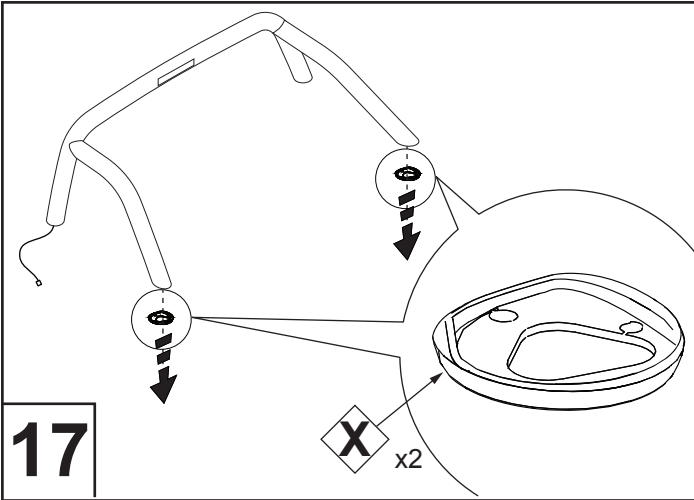

17

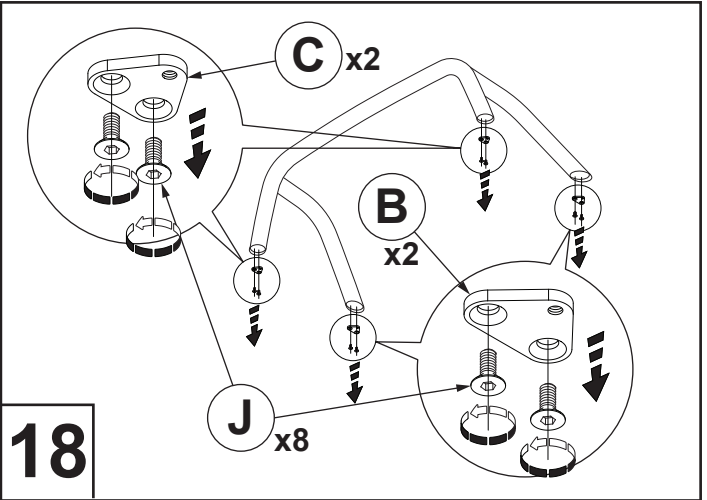

18

DO NOT allow loctite on painted or unpainted lid

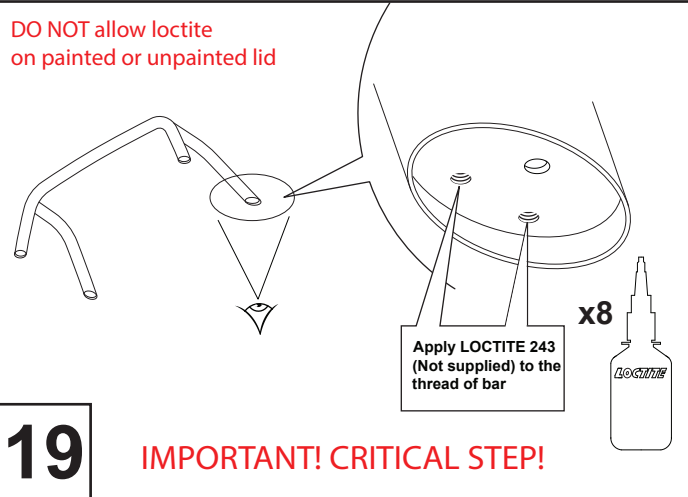

19

IMPORTANT! CRITICAL STEP!

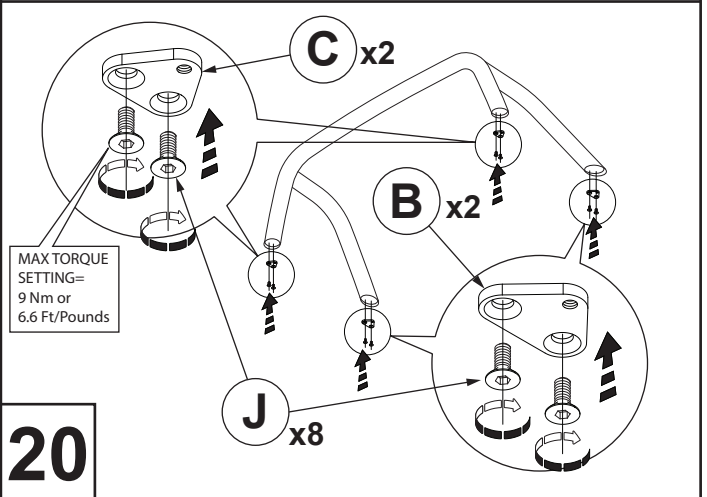

20

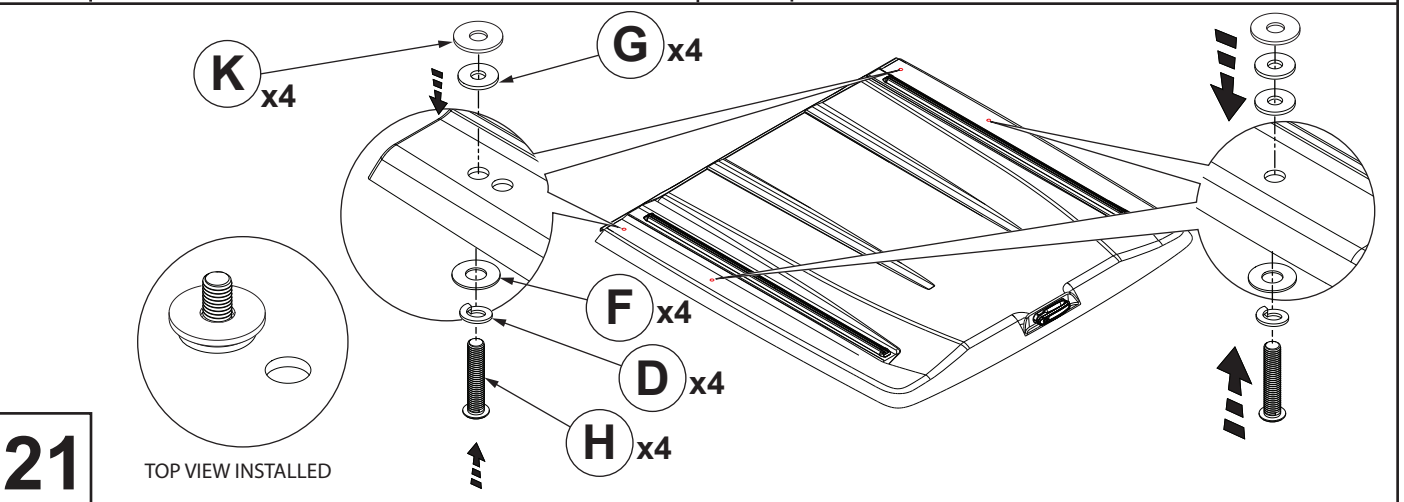

21

DO NOT allow loctite on painted or unpainted lid

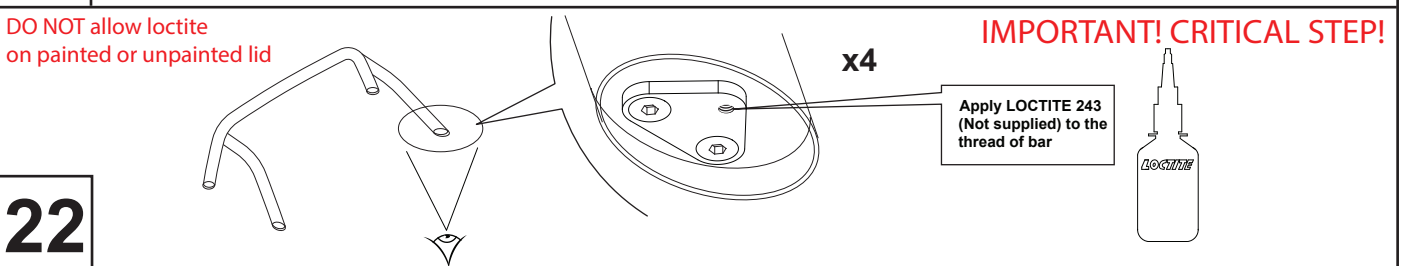

22

IMPORTANT! CRITICAL STEP!

OE BAR WITH CARGO LIGHTS = FOLLOW STEPS 26 TO 30

(Part No# FO-VGB3Z 2155106 B)

STANDARD OE BAR = FOLLOW STEPS STEP 23 TO 25

(Part No# FOAMAB3J2155174BA)

Instruction Number	Manufacturer	Model Type	Year	Stockist	Cab Size	Product	Revision	Date	Page
10055898	Ford	Ranger	2011	-	DC	Ford OE Bar	2	22-10-19	5 of 8



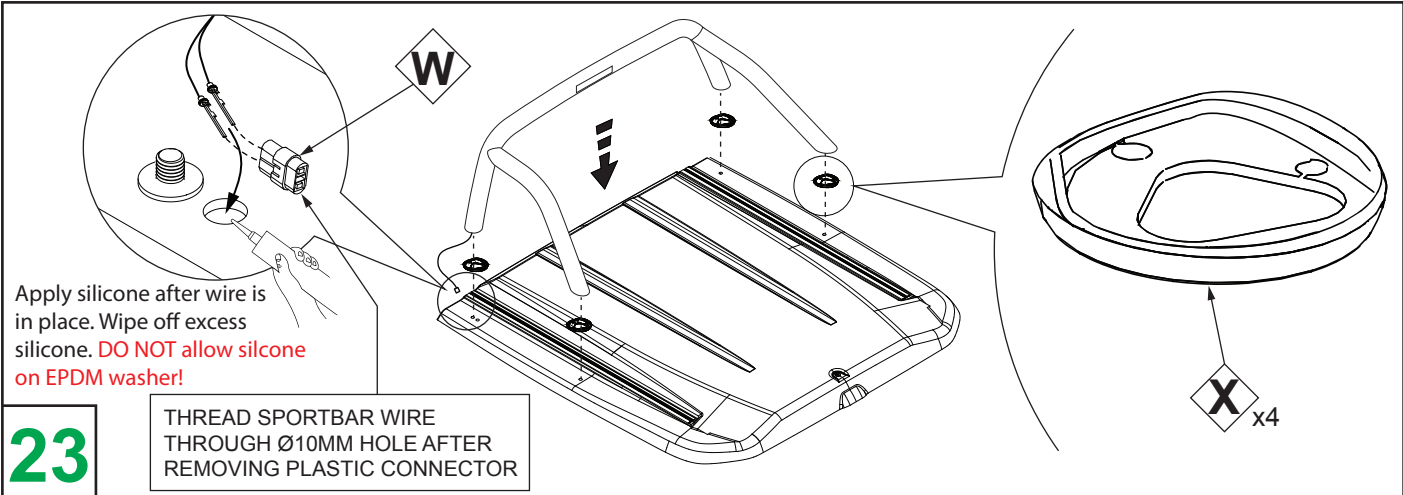

Follow fitting instruction 10055931 for fitment of PRO-FORM FORD CHMSL LOOM.

**24**

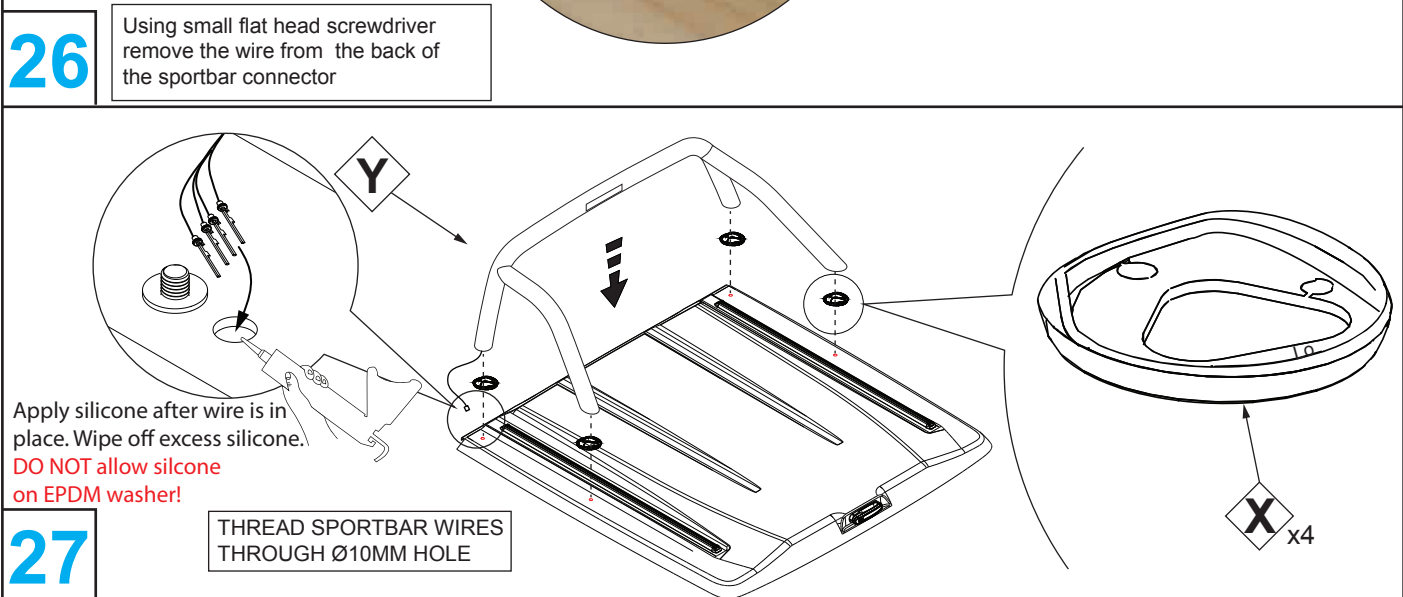
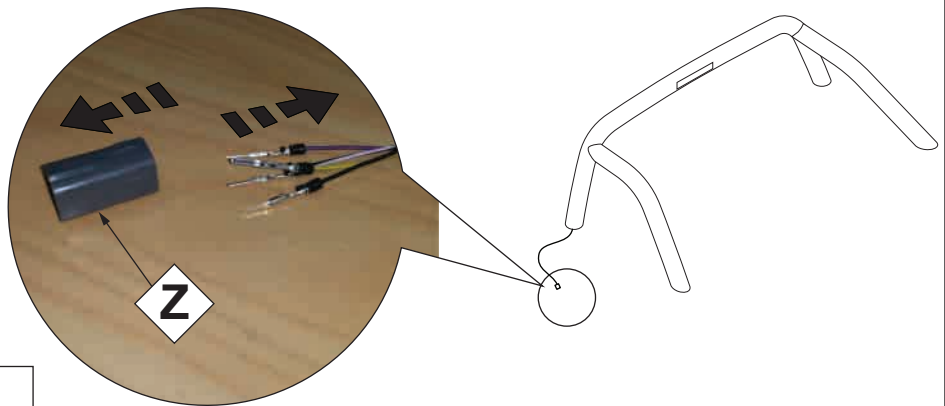
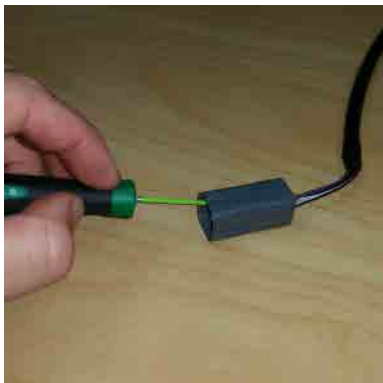
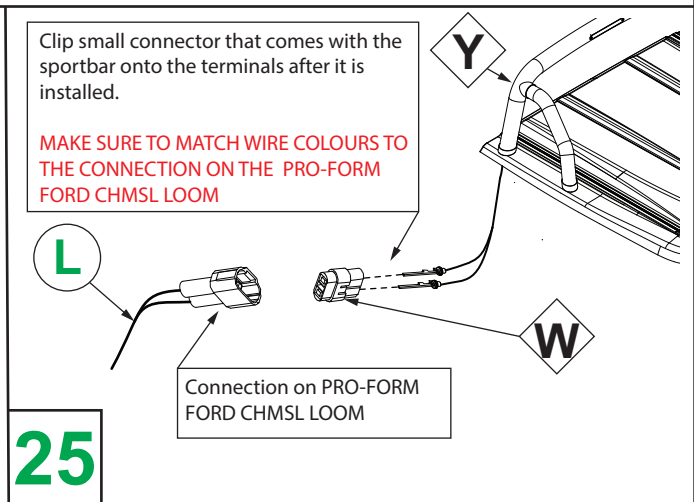

InstructionNumber	Manufacturer	Model Type	Year	Stockist	Cab Size	Product	Revision	Date	Page
10055898	Ford	Ranger	2011	-	DC	Ford OE Bar	2	22-10-19	6 of 8

28

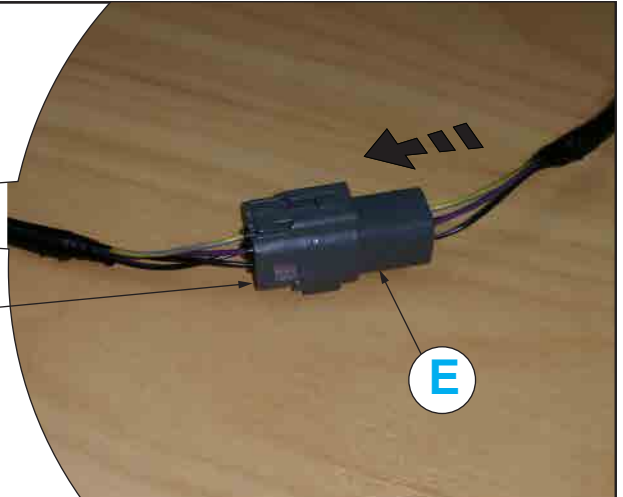
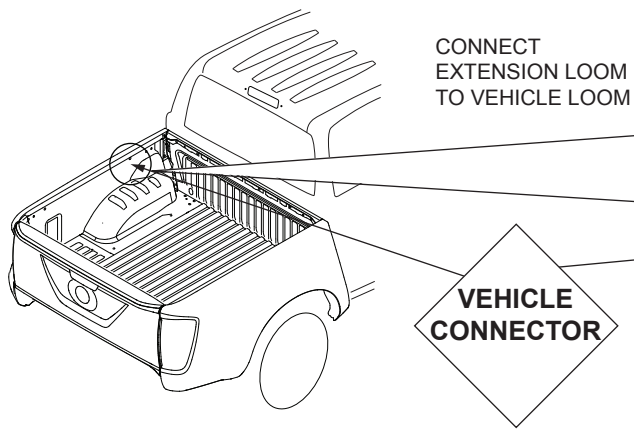

29

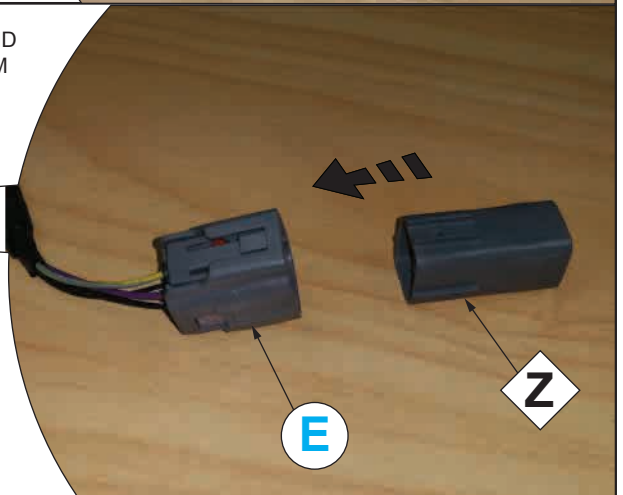
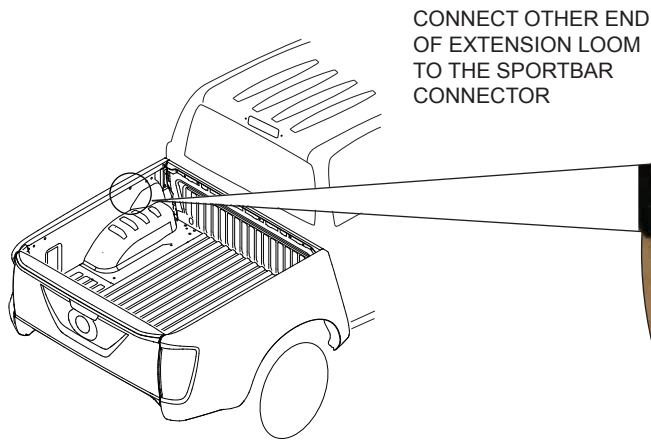

MAKE SURE TO MATCH WIRE COLOURS TO THE CONNECTION ON THE PRO-FORM FORD OE BAR 4 PIN EXTENSION

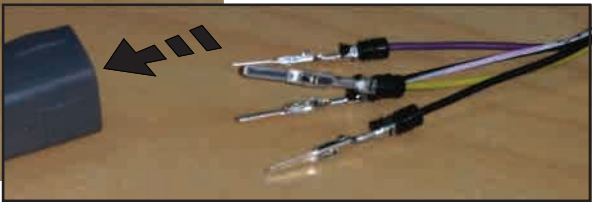

30

Feed excess SPORTBAR wire back up into the SPORTBAR then tighten 4 x bolts.

MAX TORQUE SETTING= 9 Nm or 6.6 Ft/Pounds

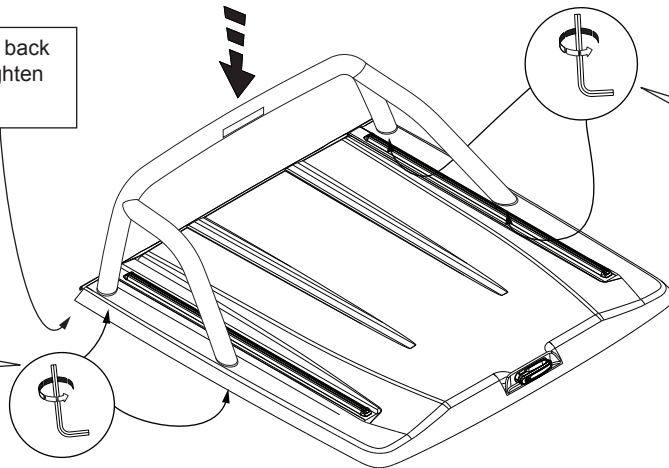

MAX TORQUE SETTING= 9 Nm or 6.6 Ft/Pounds

31

Instruction Number	Manufacturer	Model Type	Year	Stockist	Cab Size	Product	Revision	Date	Page
10055898	Ford	Ranger	2011	-	DC	Ford OE Bar	2	22-10-19	7 of 8

32

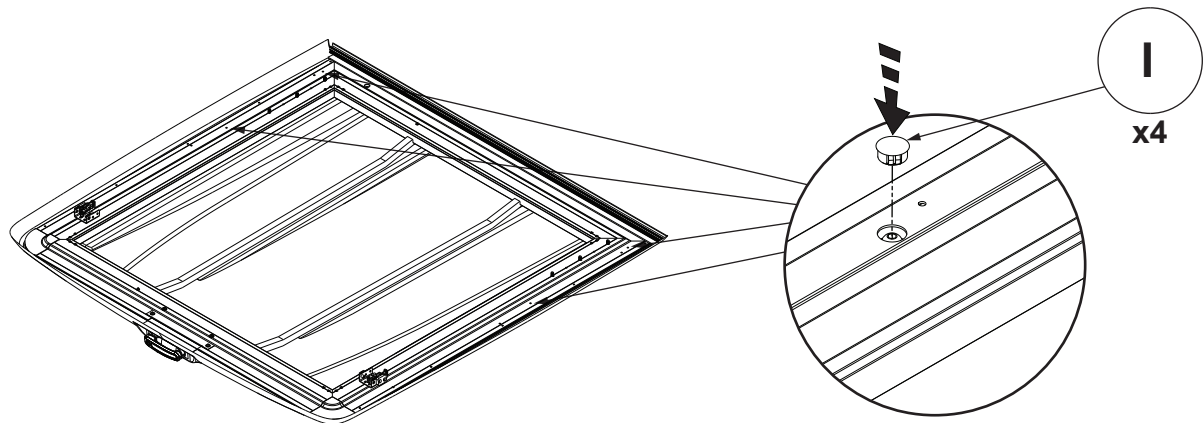

Continue installation using fitting instructions for the SPORTLID V fitment

Instruction Number	Manufacturer	Model Type	Year	Stockist	Cab Size	Product	Revision	Date	Page
10055898	Ford	Ranger	2011	-	DC	Ford OE Bar	2	22-10-19	8 of 8