

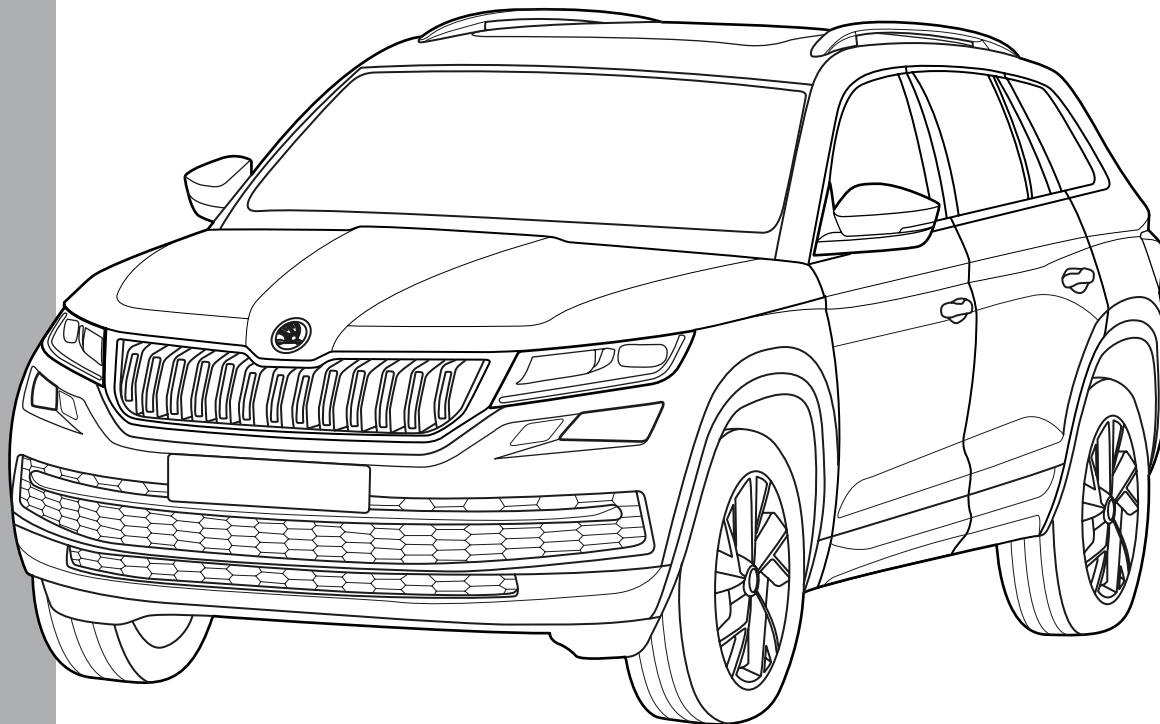

TREKHAKEN • ATTELAGES • ANHÄNGERVORRICHTUNGEN • TOWBARS • ENHANCES • ANHÆNGERTRÆK  
Montagehandleiding | instructions de montage | Einbauanleitung | Mounting instruction  
Instrucciones de montaje | monteringsvejledning

## Skoda Kodiaq

03/'17-



## Seat Tarraco

09/'18-

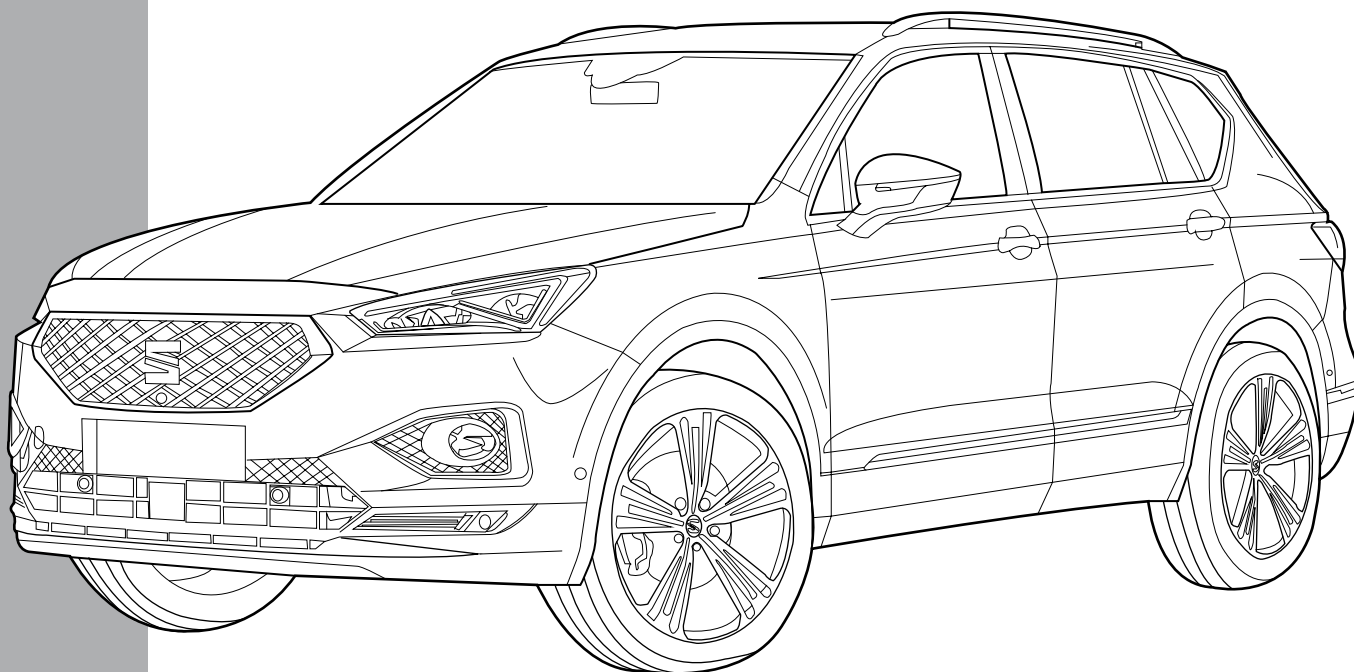





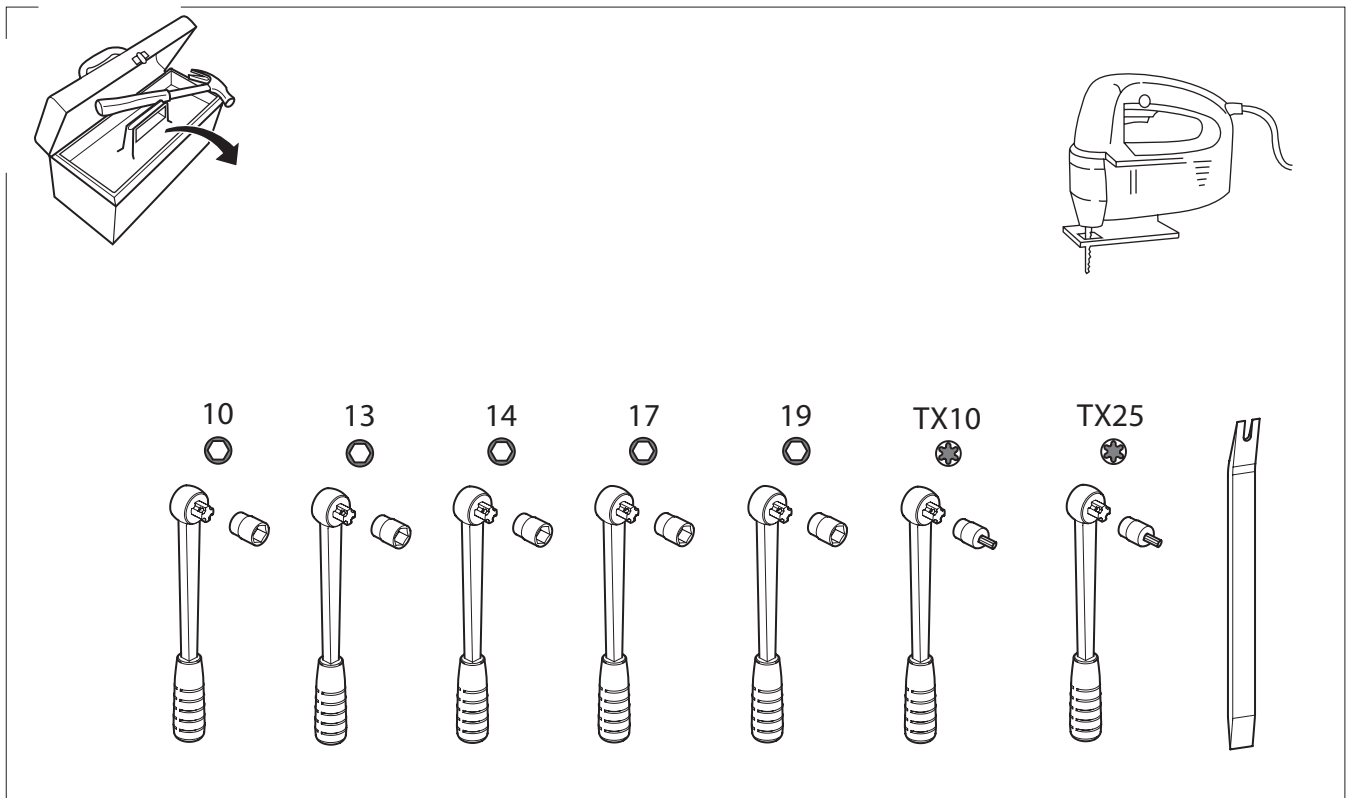
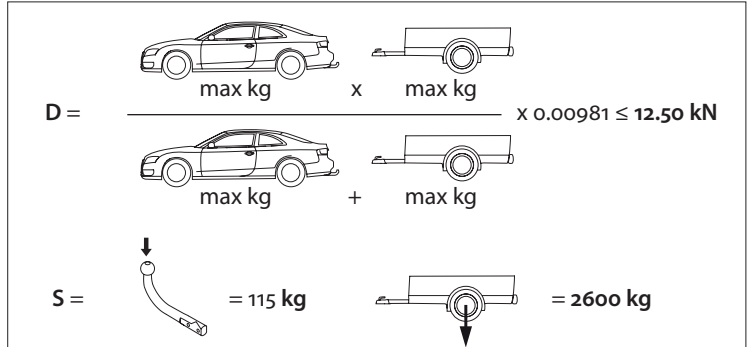

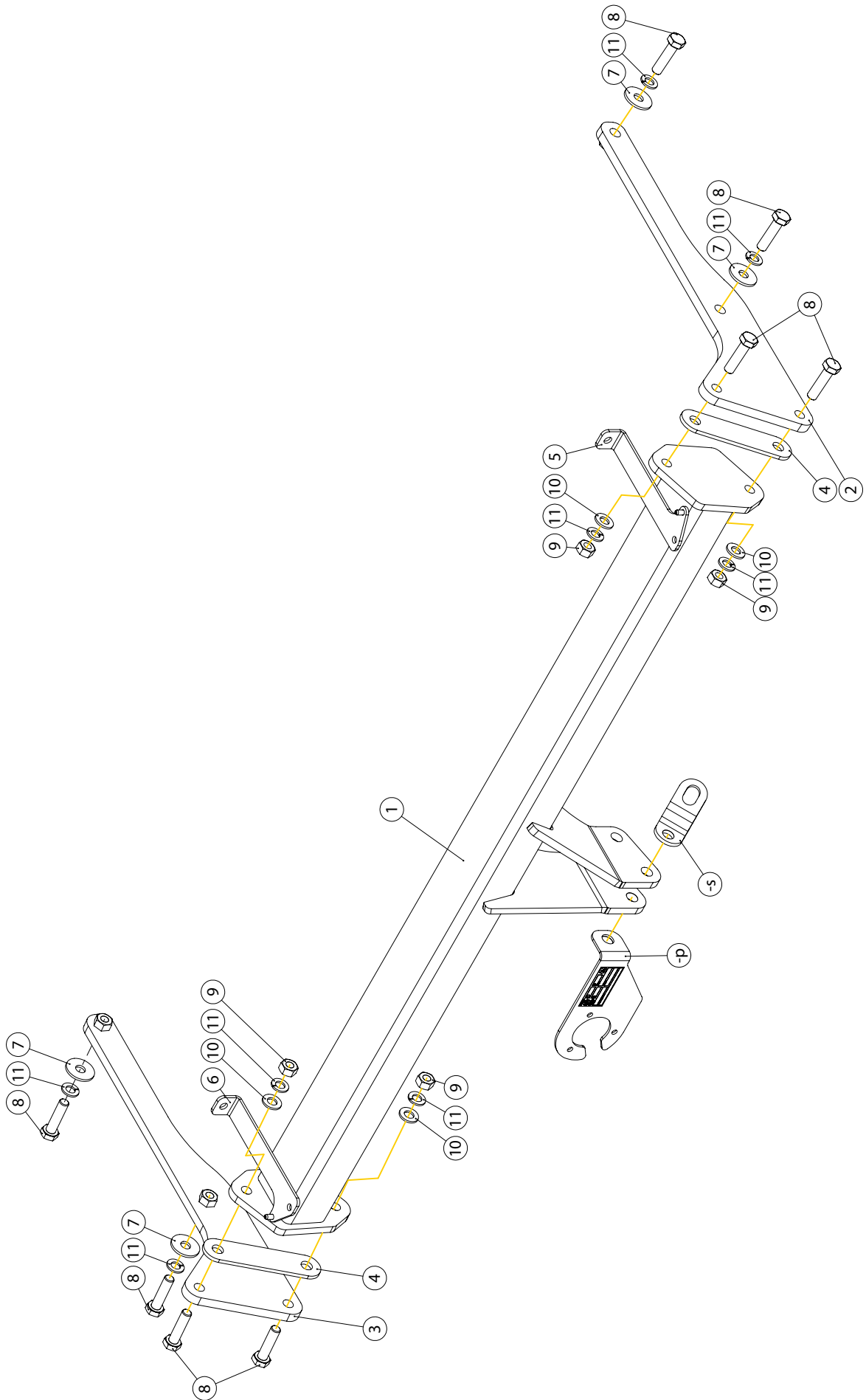

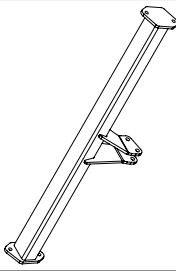
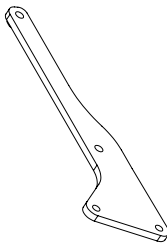
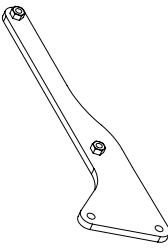
See the Certificate Of Conformity (COC) of your vehicle or contact your dealer to verify the max. trailer weight of your car!

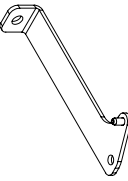
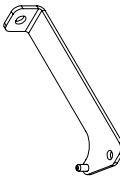

<b>D 12,50</b>	<b>F</b>	<b>E6</b>
<b>S 115</b>	EC APPROVAL N° <b>55R-011383</b>	
REF N° 2219	SERIE N°	
OMSCHRIJVING Skoda Kodiak 03/'17- & Seat Tarraco		



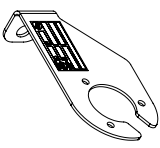

1		X1	REF. 2219
2		X1	REF. 2
3		X1	REF. 3
4		X2	REF. 4
5		X1	REF. 5
6		X1	REF. 6
7		X4	DIN9021-M10- ELVZ
8		X8	DIN 933-M10X40
9		X4	DIN 934-M10
10		X4	DIN125-A10-140HV- ELVZ
11		X8	DIN 128A-M10
-5		X1	REF. 900.053

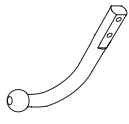
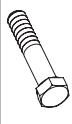
-P		X1	P07
----	---	----	-----

Geleverd met - Livré avec - Delivered with Geliefert mit - Elementos adjuntos-Leveres med		X1	944.K008
		X2	DIN931-M12 X70
		X2	DIN985-M12

1

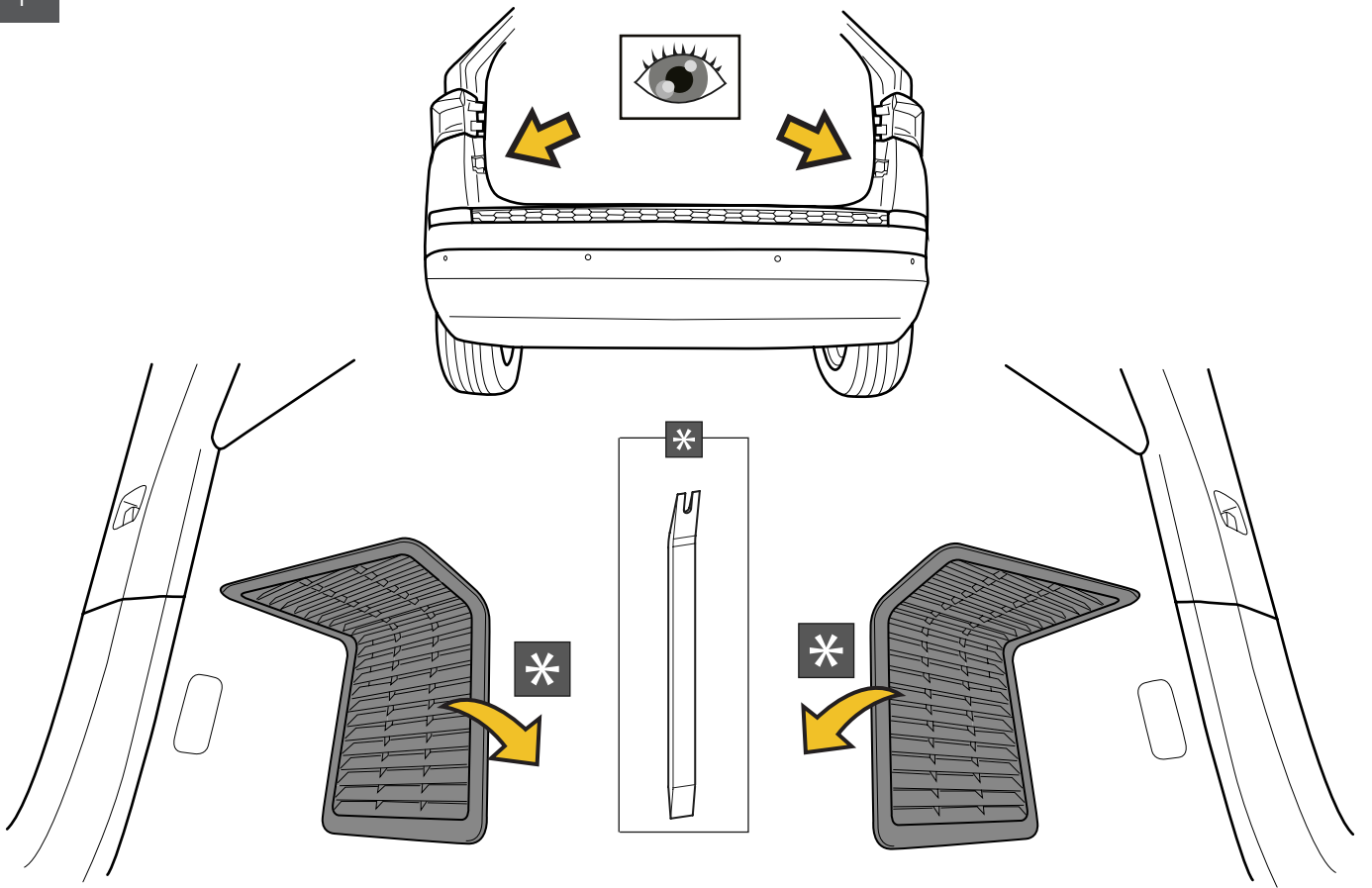

2

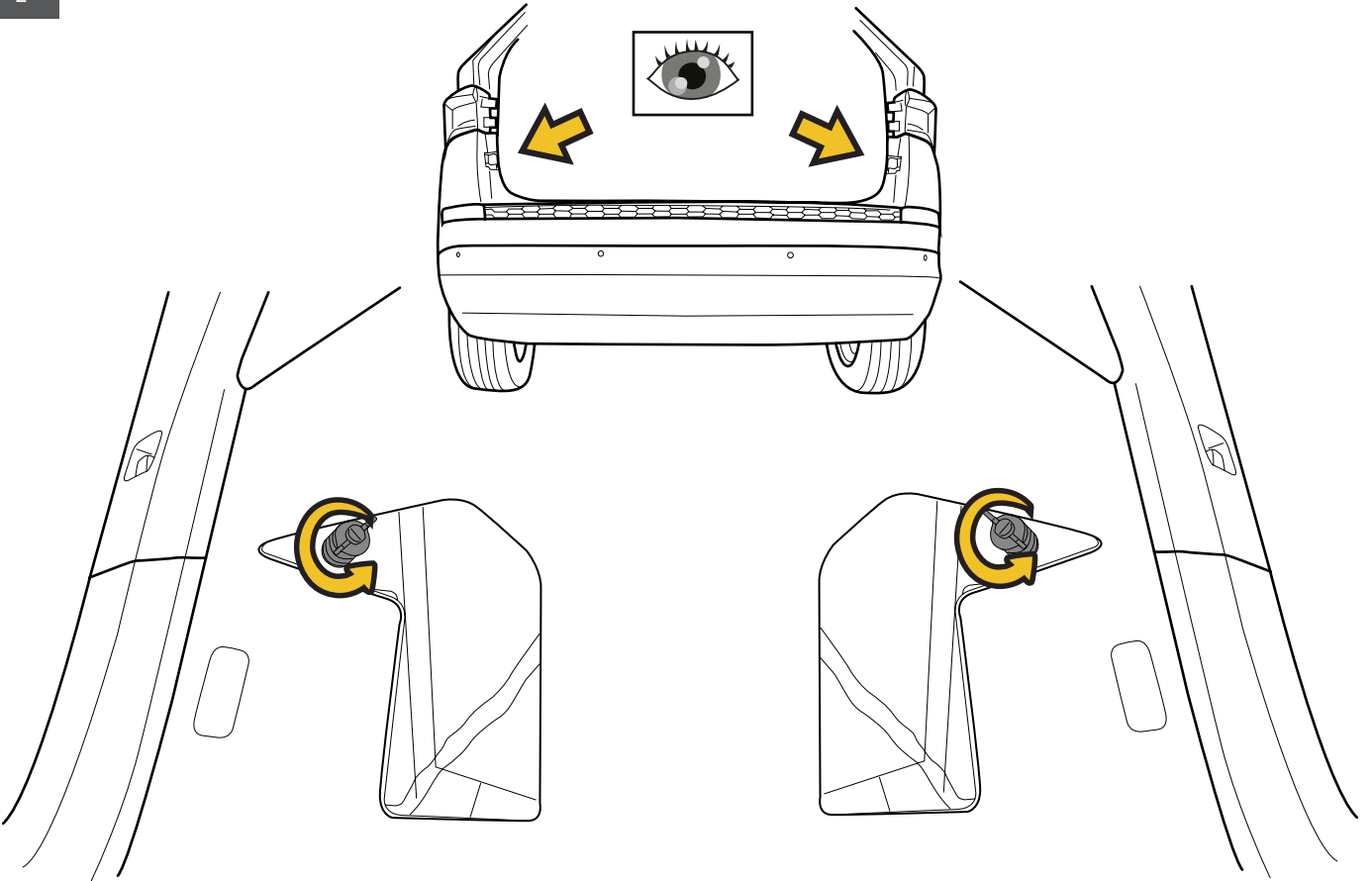

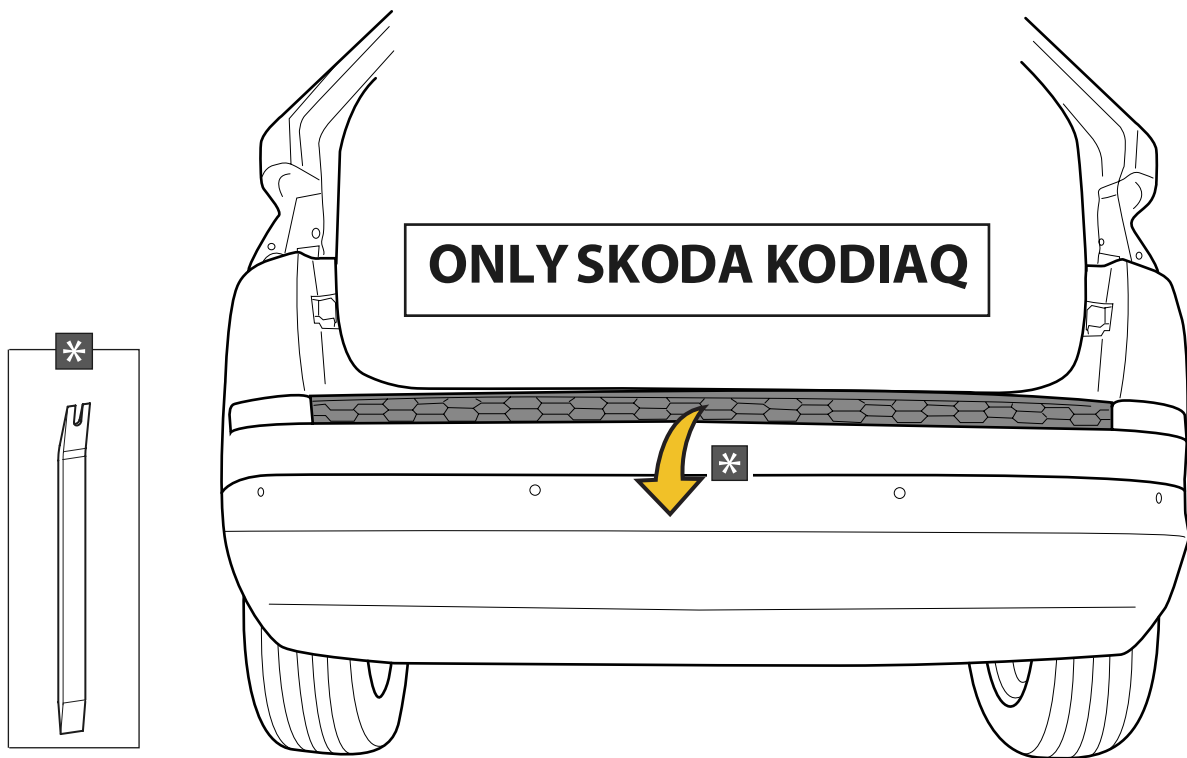
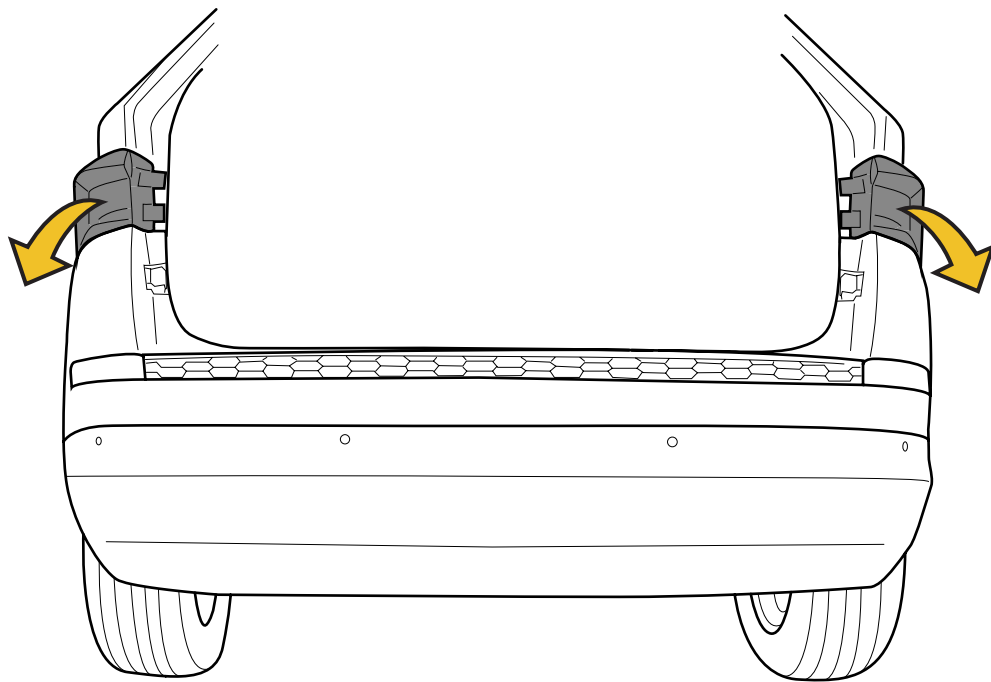

**ONLY SKODA KODIAQ**

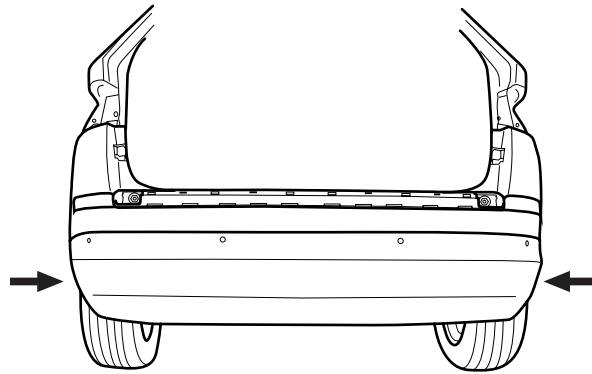
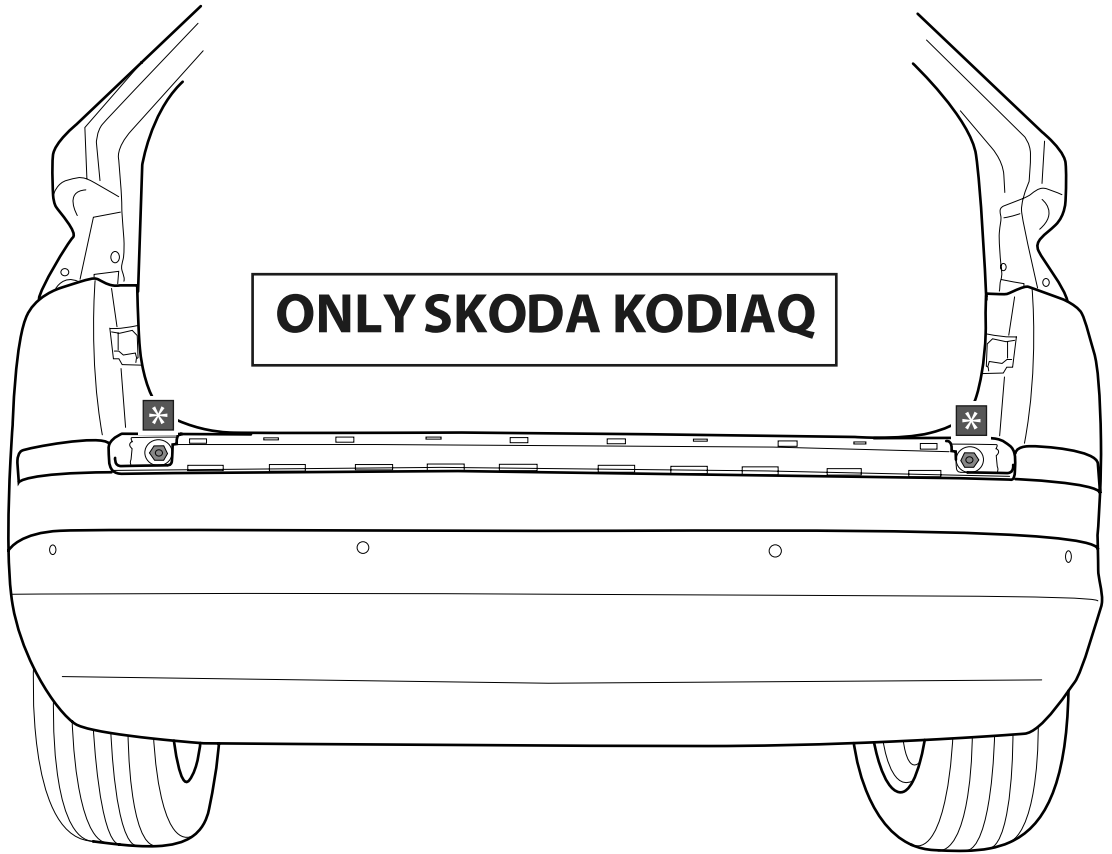
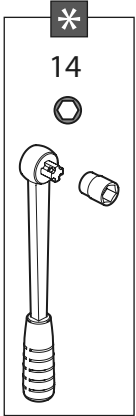

1

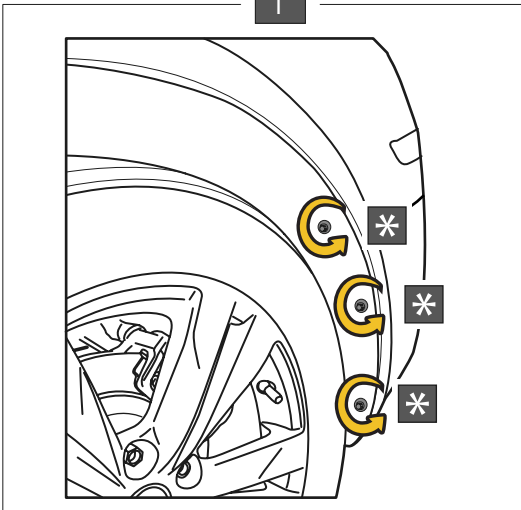

2

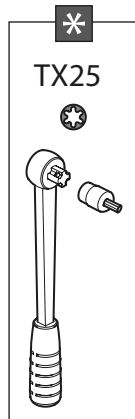
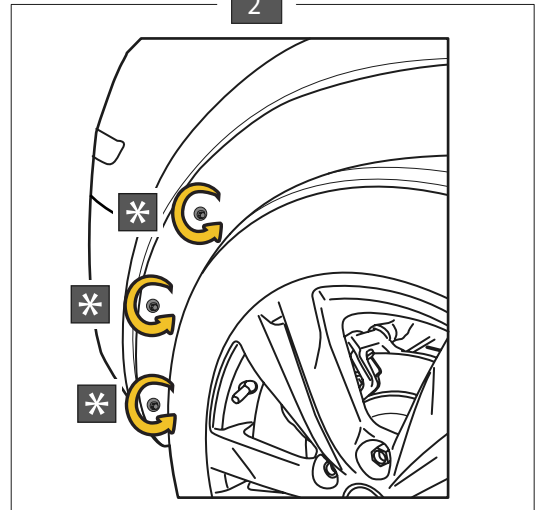

7

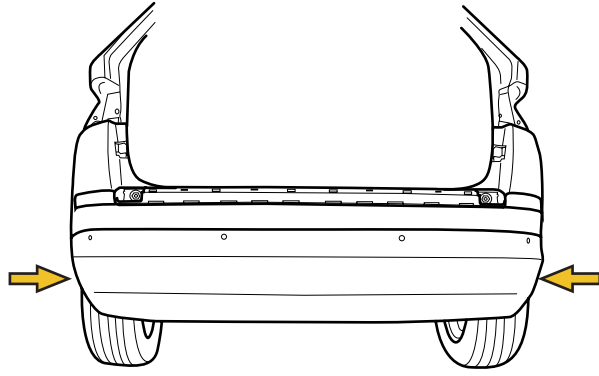

1

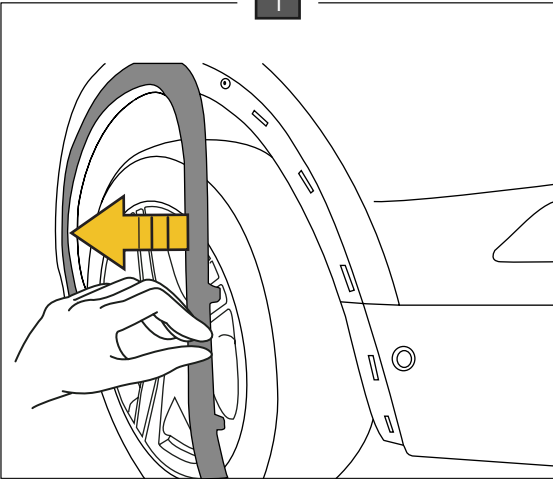

2

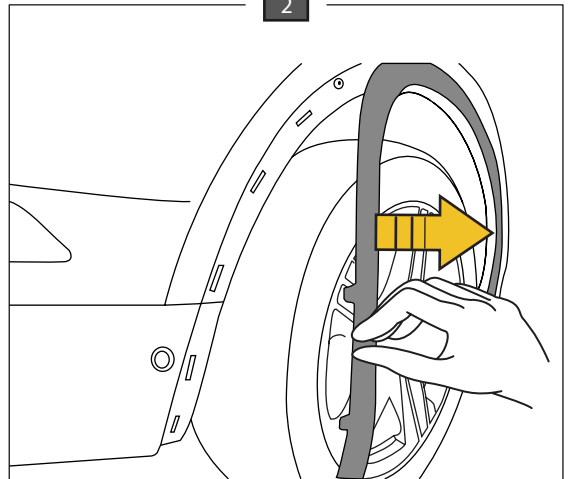

8

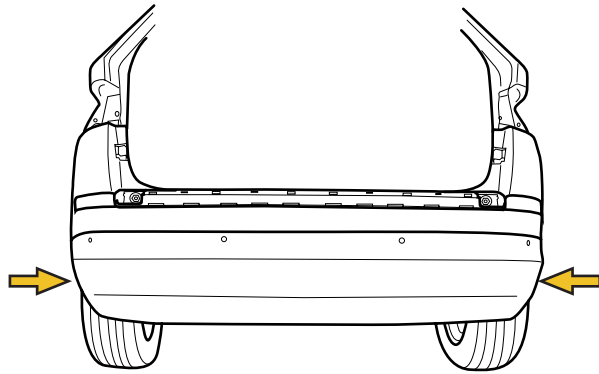

1

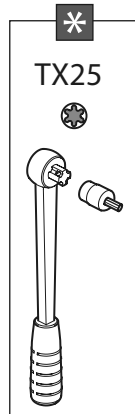
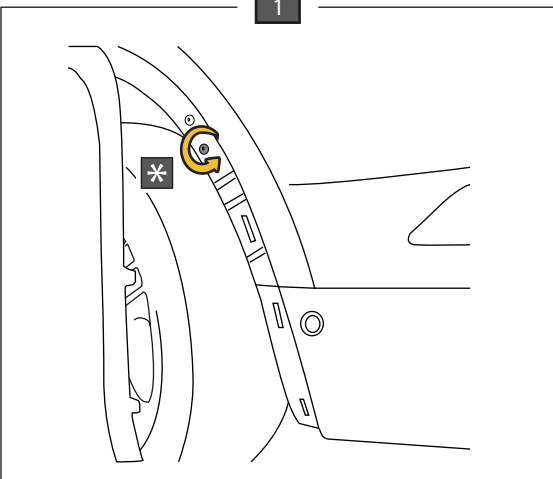

2

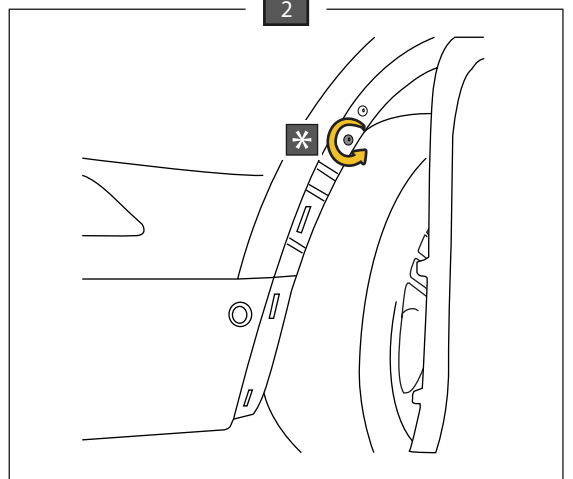

9

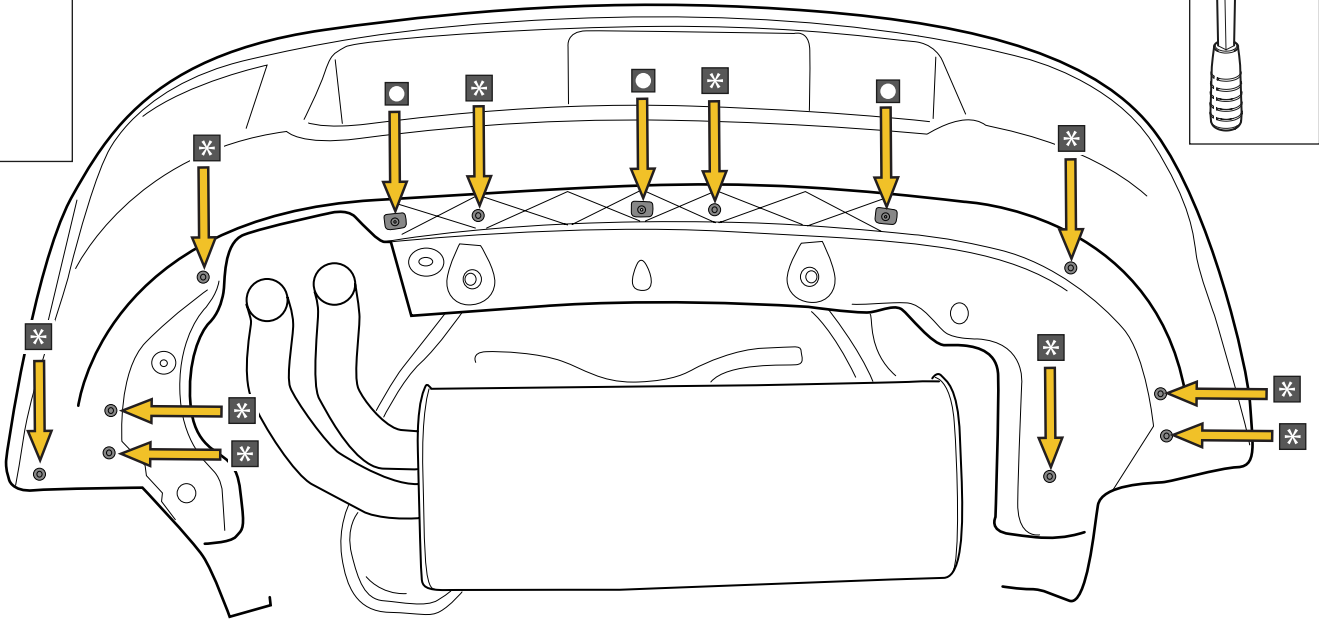
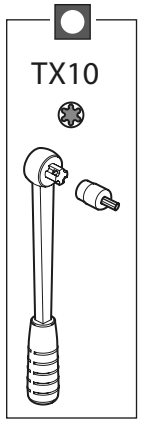
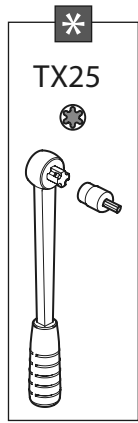

10

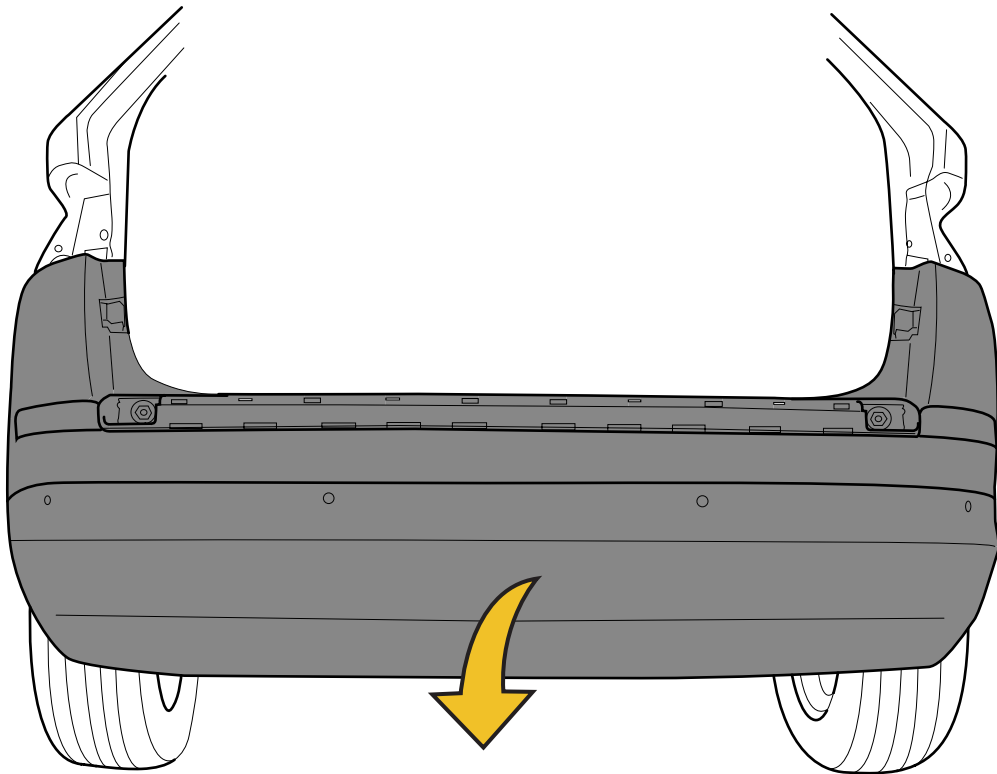

11

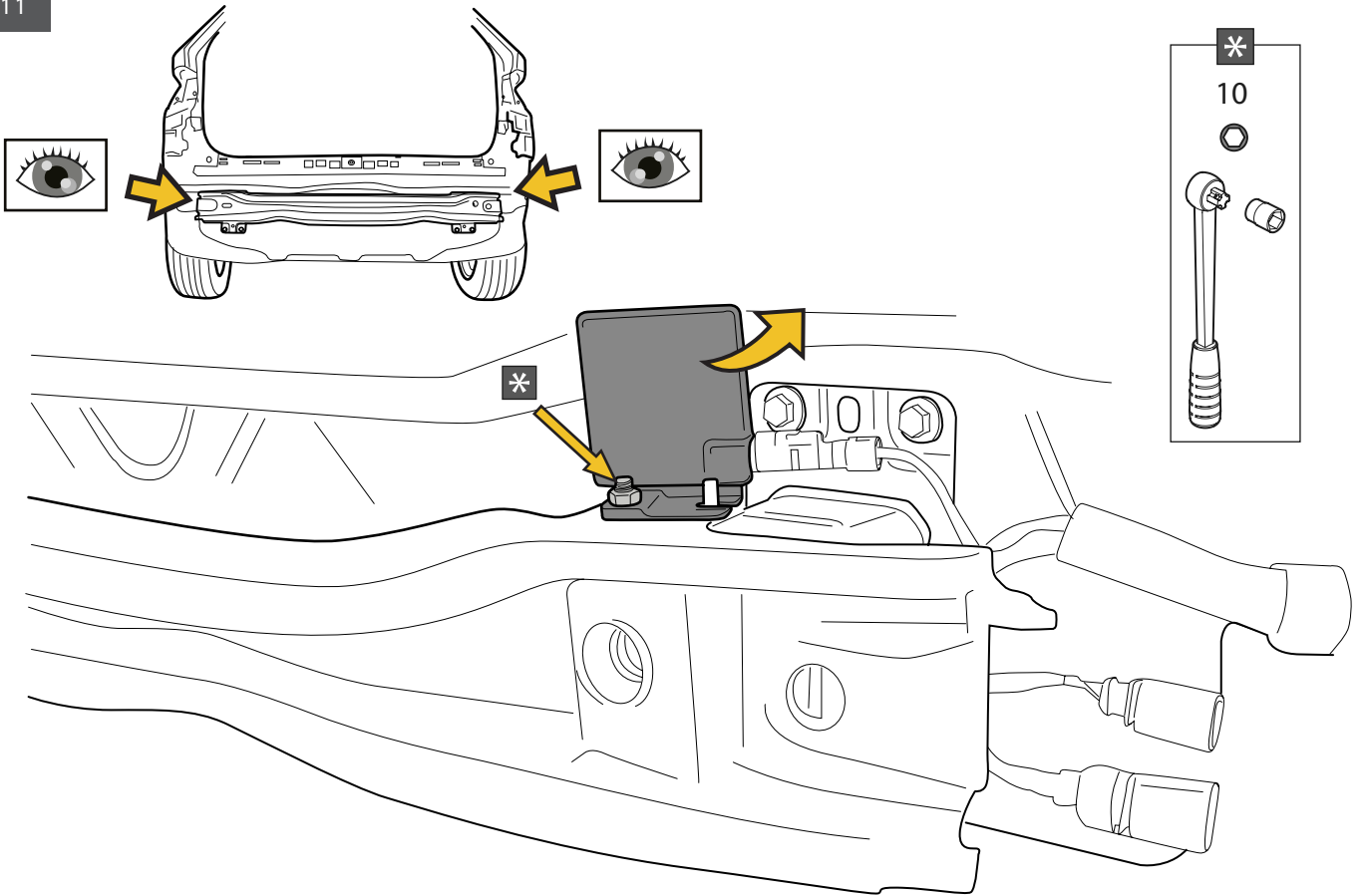

12

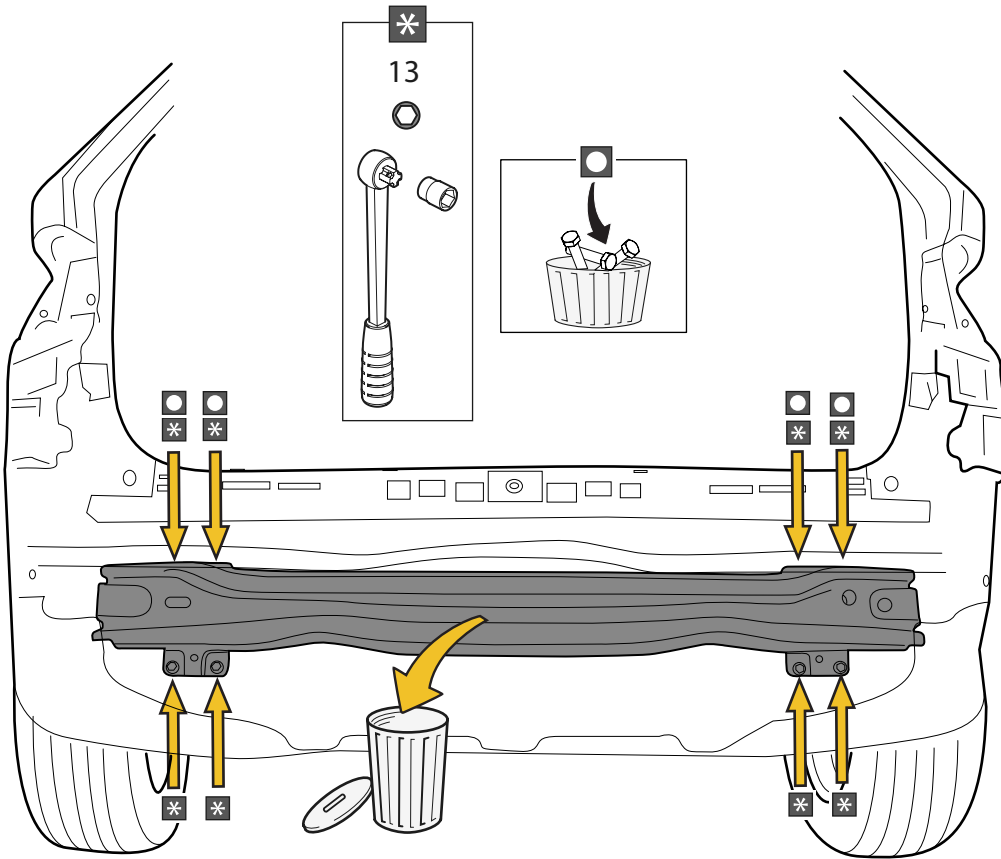

### VEHICLE WITHOUT SENSOR(S)

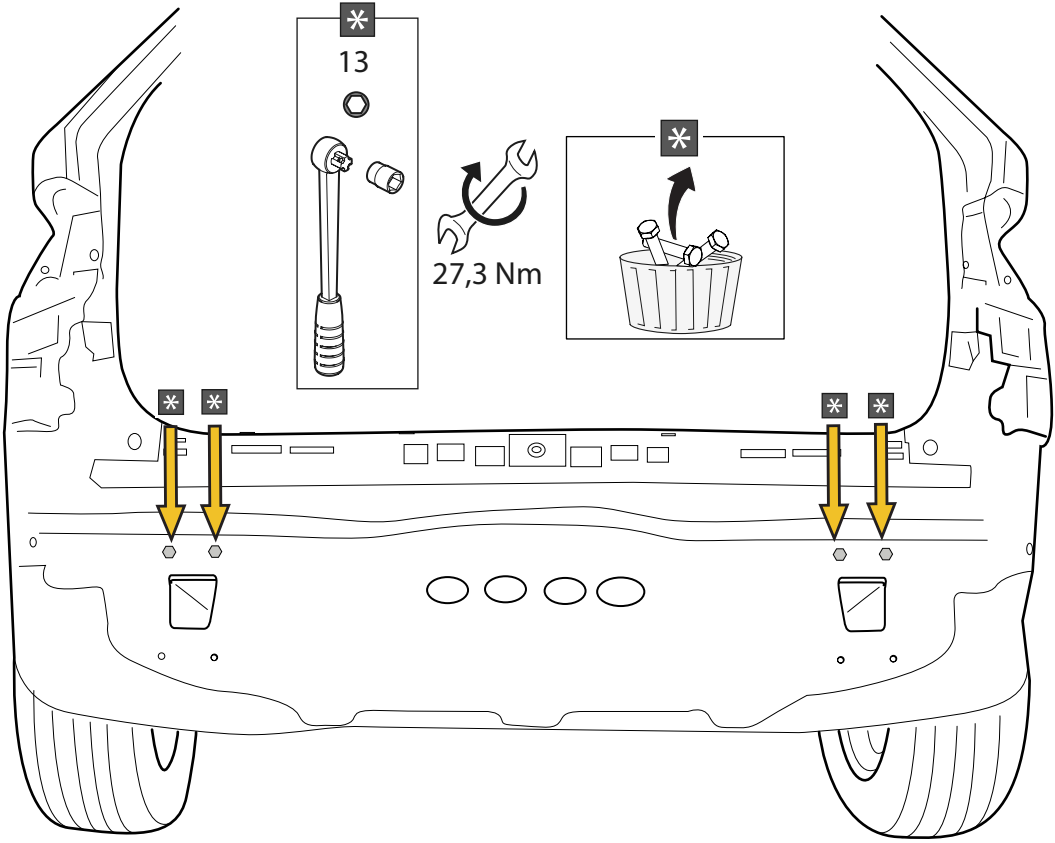

### VEHICLE WITH SENSOR(S)

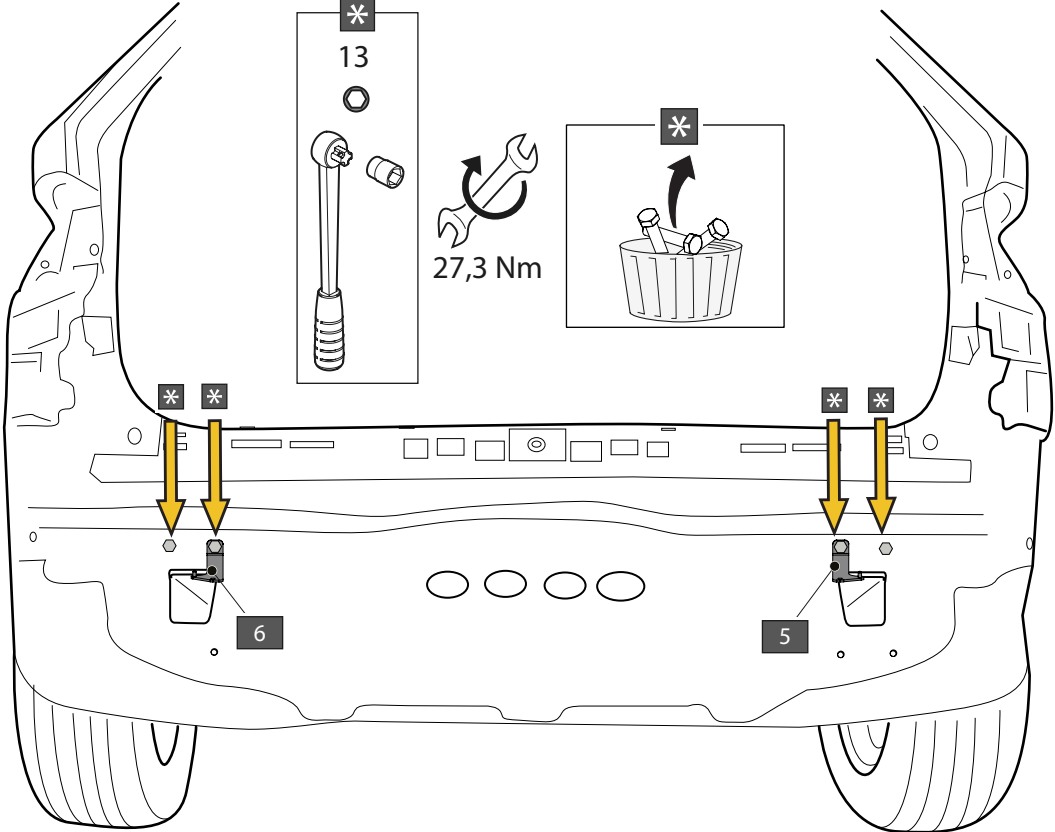

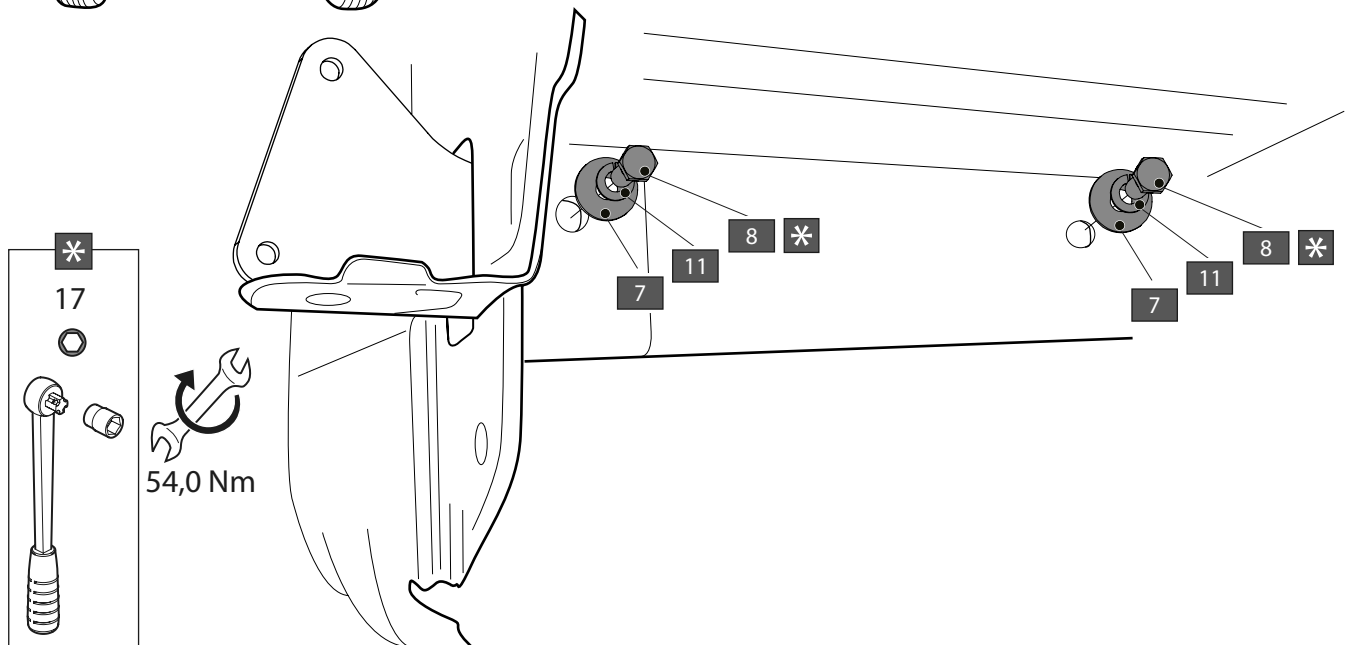
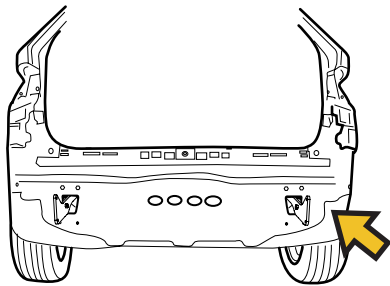
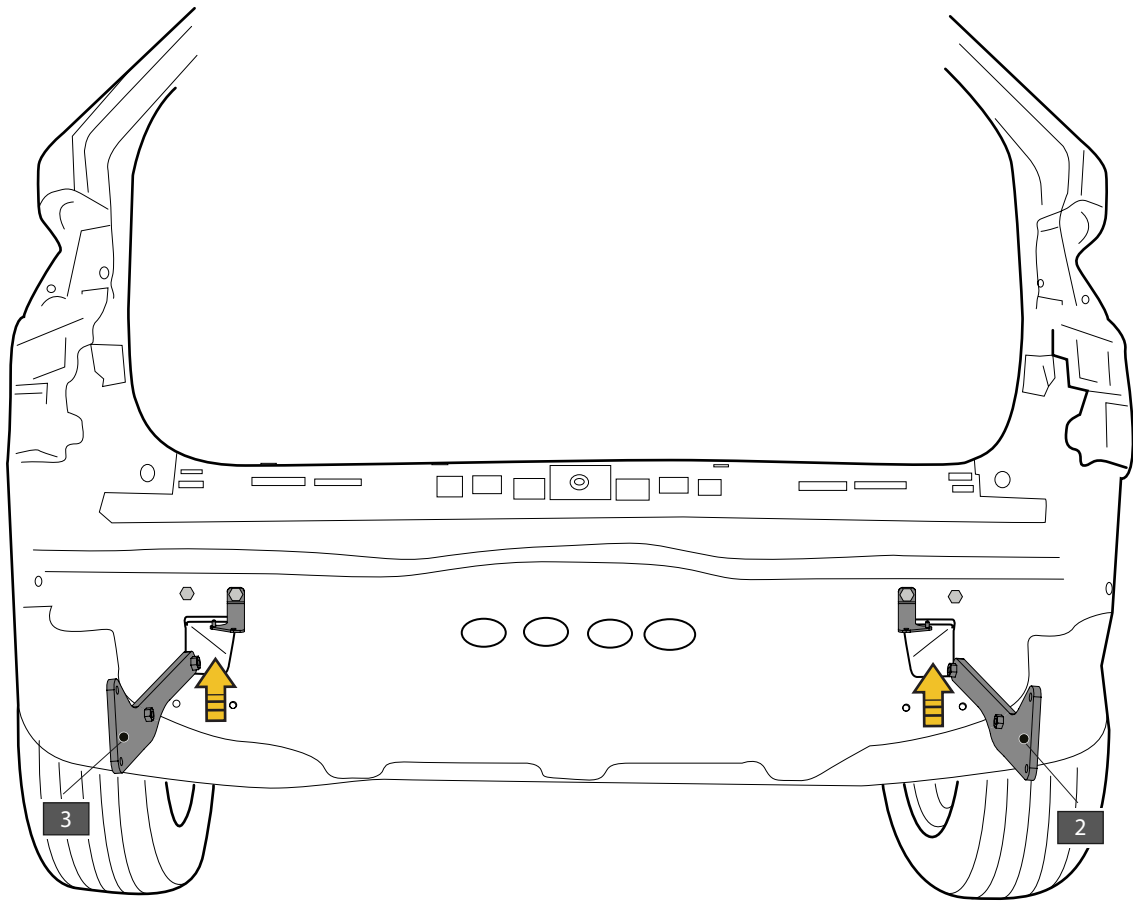

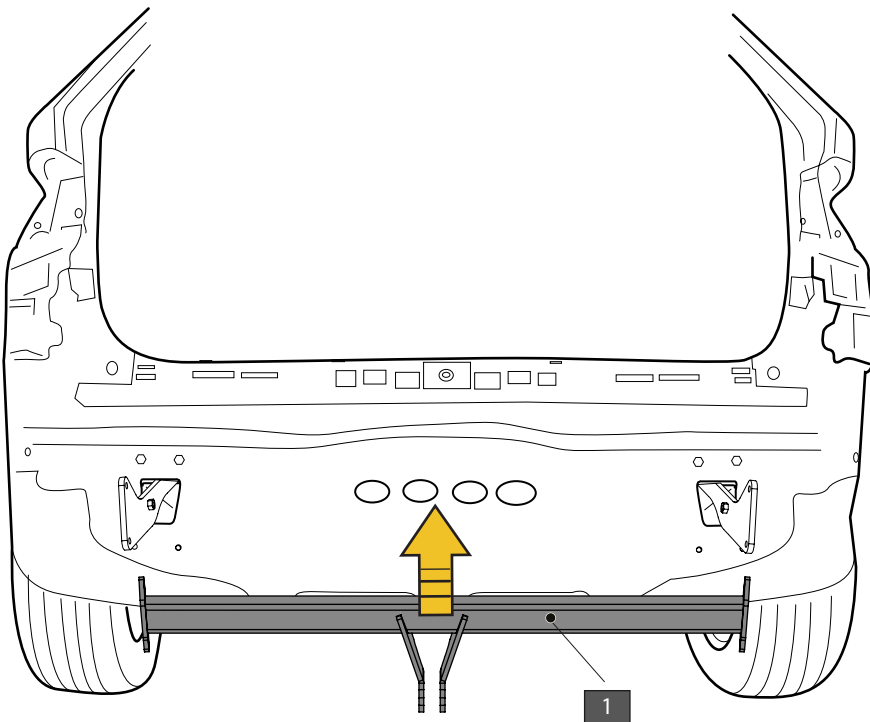
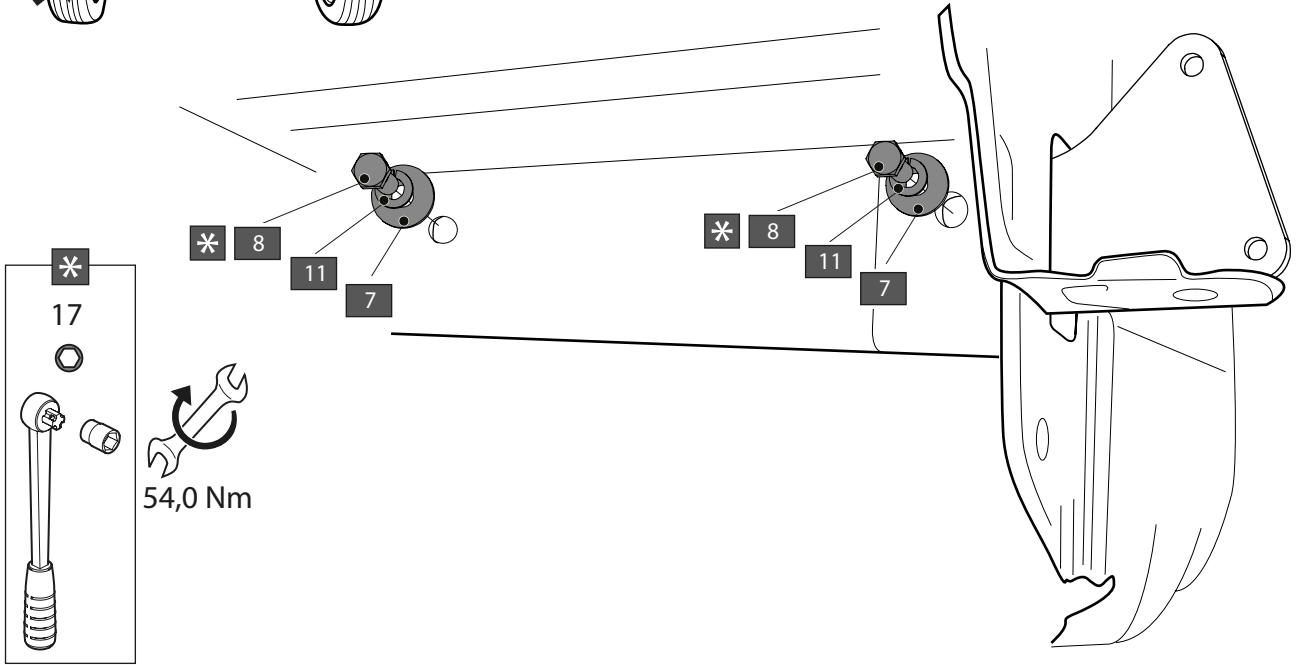
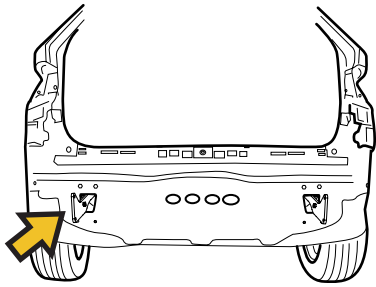

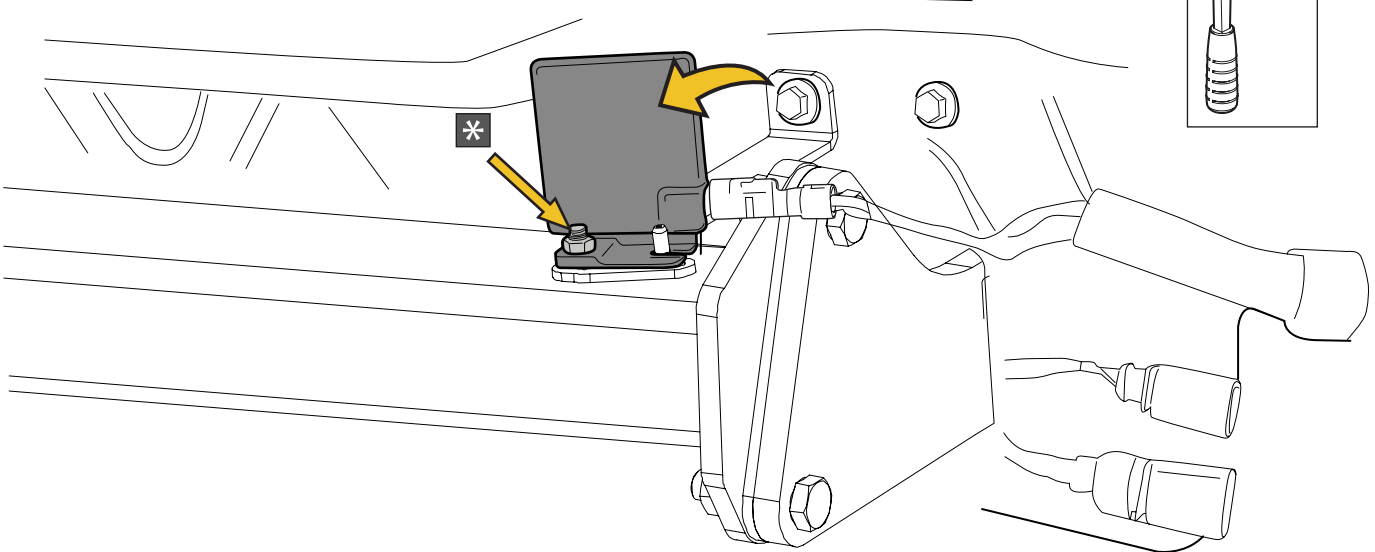
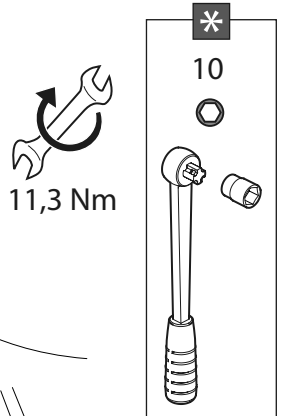
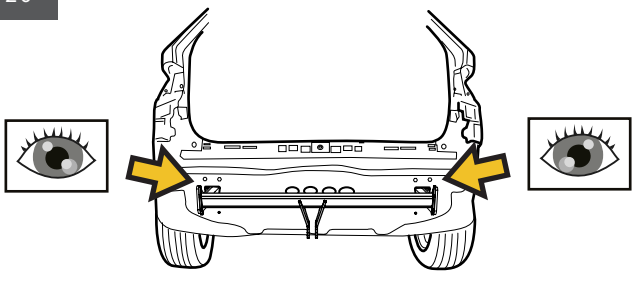
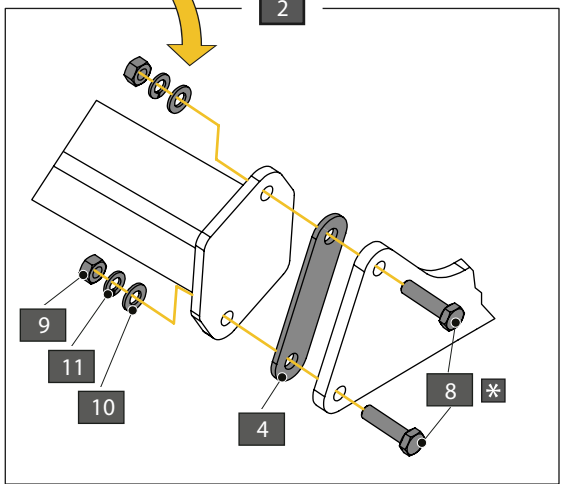
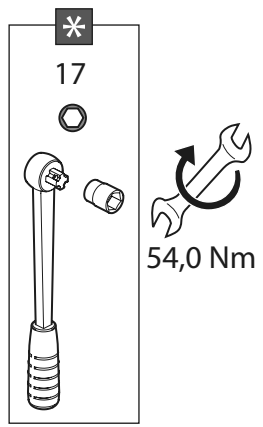
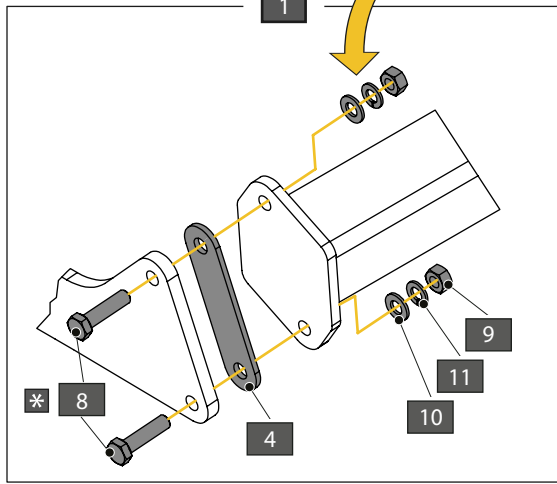
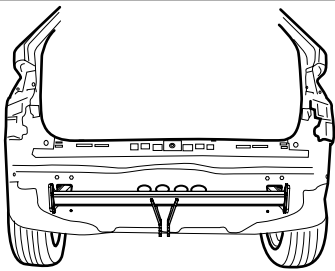
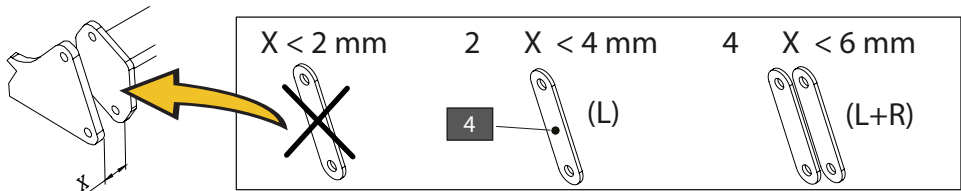

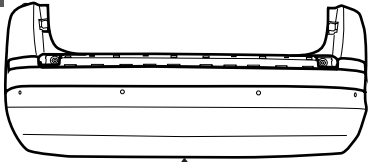

**FOR VEHICLES WITHOUT PROVIDED OPENING**

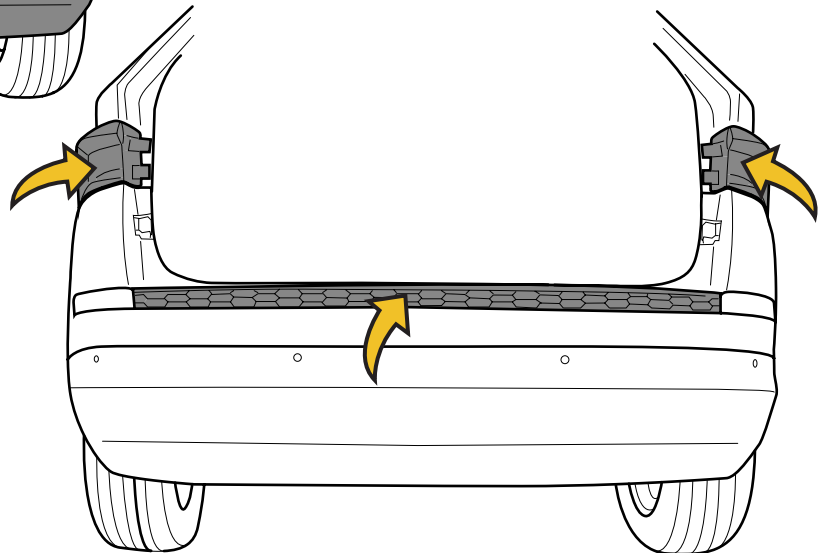
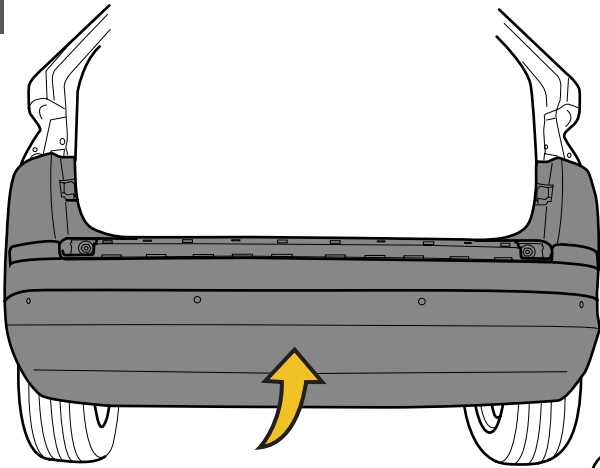
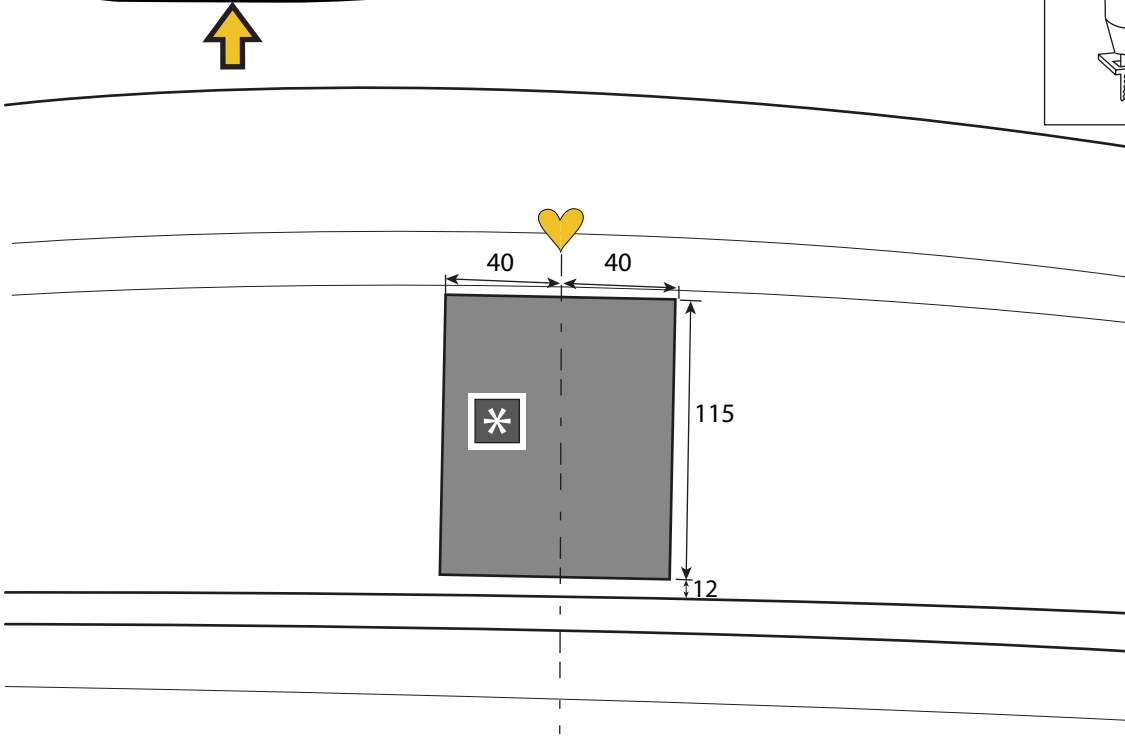
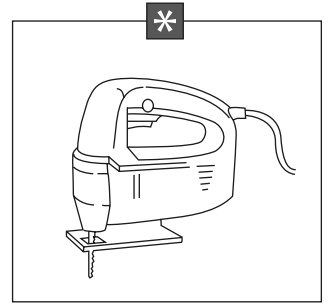

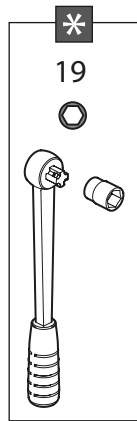
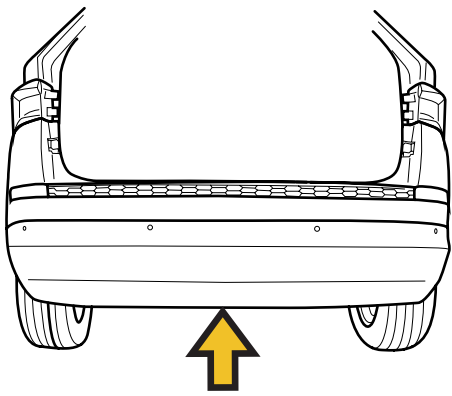

93,0 Nm

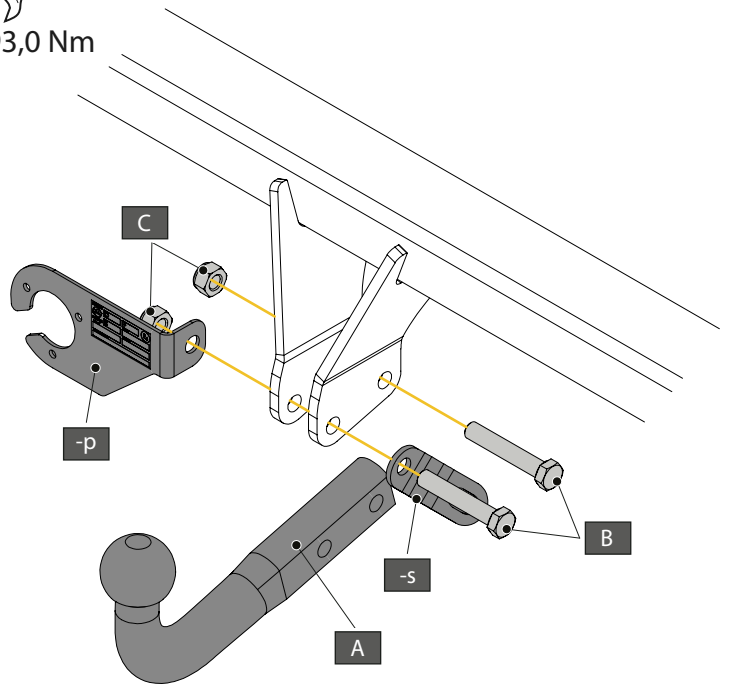

A		X1	944.K008
B		X2	DIN931-M12 X 70
C		X2	DIN985-M12
-S		X1	REF. 900.053



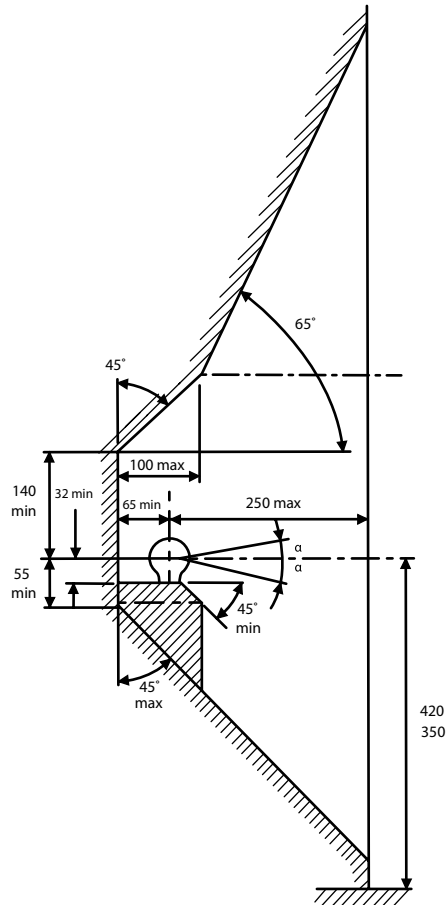

De tussenruimte conform bijlage VII, afbeelding 25 (a, b) van het reglement nr. 55-01 UN/ECE moet in acht genomen worden. Deze voorschriften zijn niet van toepassing op terreinvoertuigen klasse G.

La zone de dégagement doit être garantie conformément à l'annexe VII, illustration 25 (a, b) de la règle n° 55-01 UN/ECE. Ces dispositions ne s'appliquent pas aux véhicules tout-terrain classe G.

The clearance specified in appendix VII, diagram 25 (a, b) of regulation nr. 55-01 UN/ECE must be guaranteed. These requirements shall not apply to all-terrain vehicles class G.

Der Freiraum nach Anhang VII, Abbildung 25 (a, b) der Regulierung nr. 55-01 UN/ECE ist zu gewährleisten. Diese Vorschriften gelten nicht für Geländefahrzeugen Klasse G.

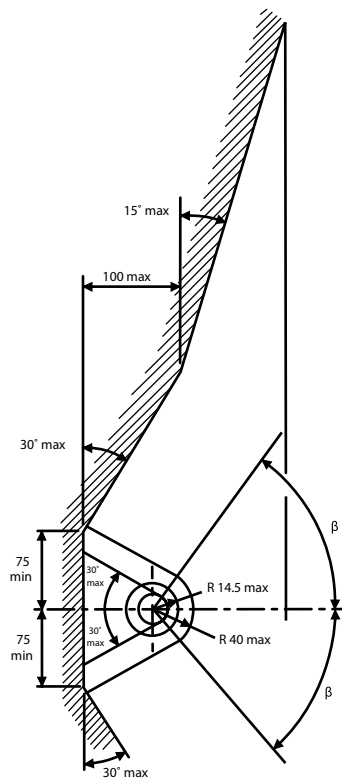

Bij toelaatbaar gewicht van het voertuig

Pour poids total en charge autorisé du véhicule

At laden weight of the vehicle

Bei zulässigem Gesamtgewicht des Fahrzeuges

Peso total admisible del vehículo

Ved tilladt samlet vægt for køretøjet

Peso totale ammissibile del veicolo